



estiluz®

11

NEW





[www.estiluz.com](http://www.estiluz.com)

**Think Green.** Environmentally friendly design. Being environmentally conscious influences our entire product's cycle. From the selection of materials and packing to light sources. Always respecting the environment. Our new collection strengthens the values of current and timeless designs, contributing to the sustainability of our planet thanks to its quality and lasting performance. Quality and design made in Europe. Estiluz is a company committed to the employment in Europe. We believe in the sustainability and quality of employment in our country. All our products are manufactured in our facilities in Sant Joan de les Abadesses. Our models are created by young and experienced designers with the support of our engineering team as well as our Design Studio. The aesthetics of design change as time goes by, good values remain.

---

**Going Green.** Design und Umwelt. Der umweltfreundliche Gedanke beeinflusst alle Vorgänge und Abläufe unserer Produkte, von der Materialien- und Verpackungsauswahl bis hin zur Verwendung von umweltfreundlichen und energiesparenden Lichtquellen. Unsere neue Leuchtenkollektion spiegelt die aktuellen, zeitlosen Designwerte wider und wirkt dank seiner Qualität und Lebensdauer bei der Nachhaltigkeit unseres Planeten mit. Qualität und Design Made in Europe. Estiluz glaubt an die Arbeitsplätze in Europa, da wir fest von der Qualität der Arbeit überzeugt sind. Die Fertigung unserer Produkte findet ausschließlich in Sant Joan de les Abadesses statt. Junge Designer kreieren unsere Modelle mit der Unterstützung unseres Ingenieurteams und Design Studios. Das Design ändert sich im Laufe der Zeit. Die guten Werte bleiben.

---

**Design et environnement.** La pensée écologique influe tout le cycle de nos produits, de la sélection des matériaux aux emballages et aux sources lumineuses. Toujours respectueux de l'environnement. Notre nouvelle collection renforce les valeurs de design actuel et intemporel, en contribuant à la protection de notre planète grâce à sa qualité et à sa durabilité. Qualité et design made in Europe. Estiluz est une société engagée pour l'emploi en Europe, nous croyons en la qualité du travail dans notre pays. Nous fabriquons dans nos installations de Saint Joan de les Abadesses nos modèles, dessinés par des jeunes créateurs expérimentés, avec le support de notre équipe d'ingénieurs et notre Bureau d'étude de Design. L'esthétique change au cours du temps. Les bonnes valeurs restent.



estiluz®

11

NEW

## Piensa Verde.

Diseño y medio ambiente. El pensamiento ecológico influye en todo el ciclo de nuestros productos, desde la selección de materiales y embalajes hasta las fuentes de luz. Siempre respetuosos con el medio ambiente. Nuestra nueva colección refuerza los valores de diseño actual y atemporal, contribuyendo a la sostenibilidad de nuestro planeta gracias a su calidad y durabilidad.

Calidad y diseño Made in Europe. Estiluz es una empresa comprometida con el empleo en Europa porque creemos en la sostenibilidad y calidad del empleo en nuestro país. Son productos fabricados en nuestras instalaciones de Sant Joan de les Abadesses, modelos creados por jóvenes y experimentados diseñadores con el apoyo de nuestro equipo de ingenieros y nuestro Estudio de Diseño. La estética del diseño cambia con el transcurso del tiempo. Los buenos valores permanecen.

# balloon t-3052

crouscalogero

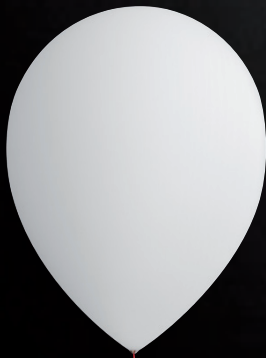

# balloon A-3050

crouscalogero

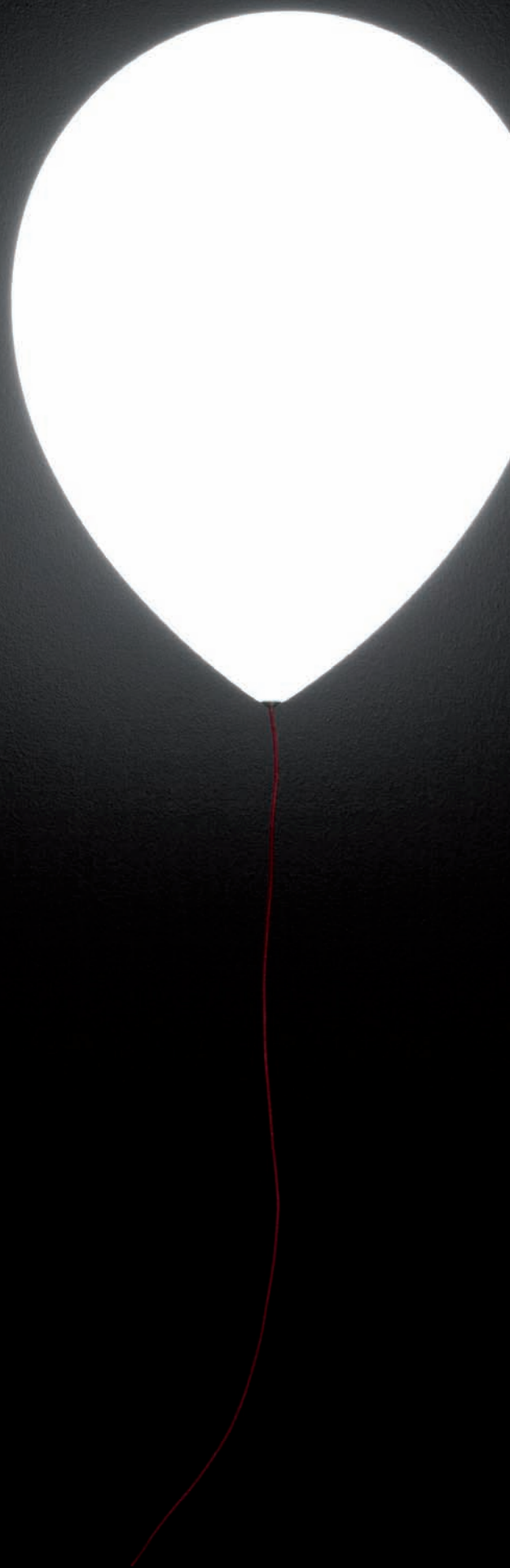

# plec A-3060 | A-3060L

guimeràicina





# siso T-2995

estudi ribaudí

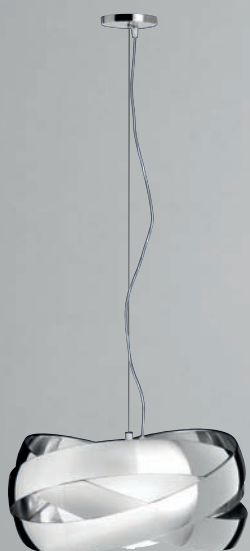

# moon A-3010

estudi ribaudí



**pluma T-2956**  
estudi ribaudí



# lungta T-3075

estudi alfred garcía gotós

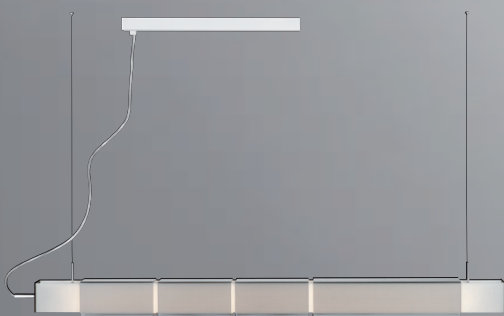

t-2600 | t-2601 | t-2601F | t-2602 | t-2602F

estudi estiluz



**outdoor**



# shadow T-2935

jordi vayreda

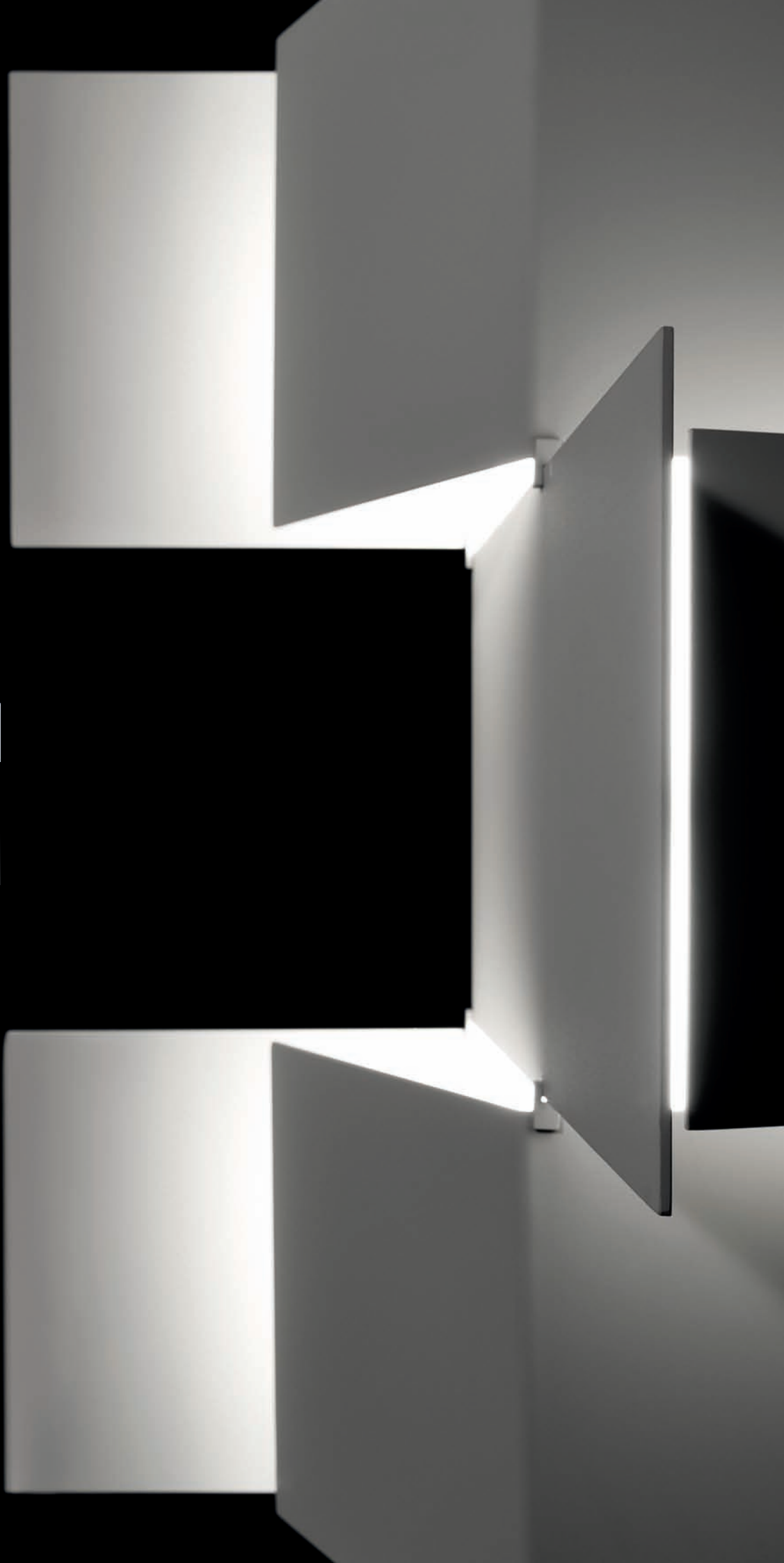

# nan A-3040X

guimeràicina





**nan M-3044X**

guimeràicina



# dot t-2902X

serra&delarocha



# dot M-2907X

serra&delarocha



**dot P-2909 | P-2909X**

serra&delarocha



**dot T-2905 | T-2905X**

serra&delarocha

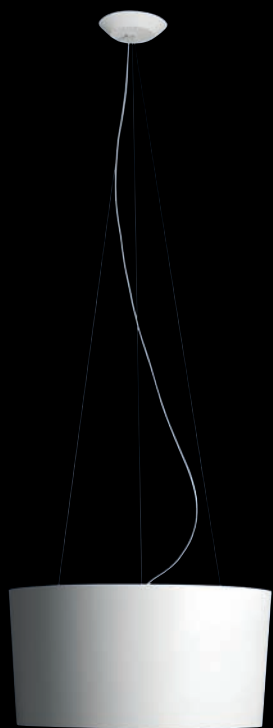

## balloon t-3052

crouscalogero



Plafón con luz directa e indirecta. Pantalla de polietileno satinado (material traslúcido).

Flushmount providing direct and indirect light. Shade is made of satinated polyethylene (translucent).

Deckenleuchte. Direktes und indirektes Licht. Satinierter Polyethylenschirm (durchscheinend).

Plafonnier lumière directe et indirecte. Abat-jour en polyéthylène blanc satiné (matériel translucide).

● 74BL

El. fluorescent | E27 | 20W | 230V | ES

CE IP 20 850°

## balloon A-3050

crouscalogero

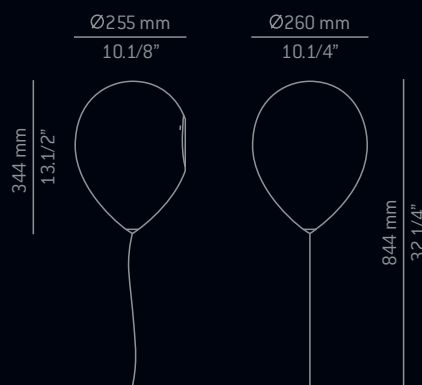

Applique con luz directa e indirecta. Pantalla de polietileno satinado (material traslúcido) e interruptor-tirador (se puede inutilizar).

Wall sconce providing direct and indirect light. Shade is made of satinated polyethylene (translucent) and pull switch in the cord (it can be disconnected).

Wandleuchte. Satinierter Polyethylenschirm (durchscheinend). Schnurschalter (wahlweise ohne Funktion).

Applique lumière directe et indirecte. Abat-jour en polyéthylène translucide blanc satiné, interrupteur à tirette (que l'on peut déconnecter si besoin).

● 74BL

El. fluorescent | E27 | 20W | 230V | ES

CE IP 20 850°

## plec A-3060 | A-3060L

guimeràinca

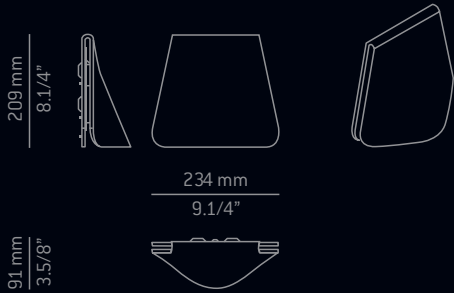

Aplicque metálico con luz indirecta.  
Metallic wall sconce providing indirect light.  
Metallwandleuchte. Indirektes Licht.  
Applique en métal. Lumière indirecte.

●●● 20ALR76BL MR88ANNI

### A-3060

Hal. | R7s | 78 mm | ECO 100W | 230V

### A-3060L

LED 14W (warm white) ES

CE

## siso T-2995

estudi ribaudí

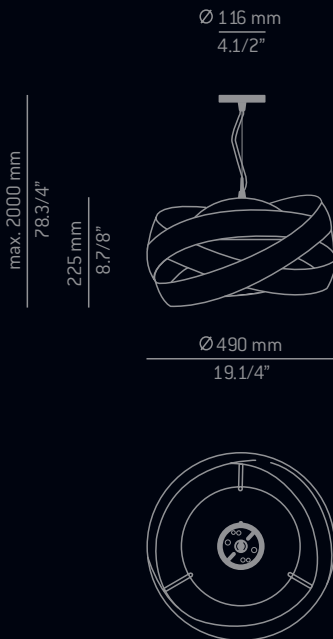

Lámpara de techo con luz directa e indirecta. Pantalla de cristal blanco satinado y anillos decorativos de aluminio. Altura regulable.

Pendant providing direct and indirect light. Shade is made of satinated glass and decorative aluminum rings. Adjustable height.

Pendelleuchte. Direktes und indirektes Licht. Satinierter Glasschirm mit dekorativen Aluminiumringen. Höhenverstellbar.

Suspension lumière directe et indirecte avec abat-jour en verre blanc satiné et anneaux décoratifs en aluminium. Hauteur réglable.

● 22CR

Hal. | BT E27 | 3X60W | 230V   
El. fluorescent | E27 | 3X20W | 230V ES   
Inc. | E27 | 3X60W | 230V

CE

## moon A-3010

estudi ribaudí

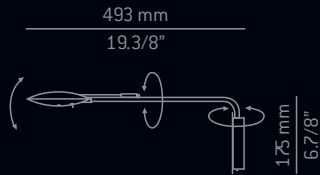

Aplique de lectura metálico. Brazo giratorio con interruptor incorporado en la pantalla.

Metallic reading wall light. Swing arm with switch built in the head.

Metallwandleuchte. Beweglicher Lesearm. Schalter am Leuchtenkopf.

Applique orientable métallique. Bras articulé avec interrupteur intégré au réflecteur.

● 22CR 26NE 37NI

LED | hi-power warm white | 4W | 230V |  ES



## pluma T-2956

estudi ribaudí

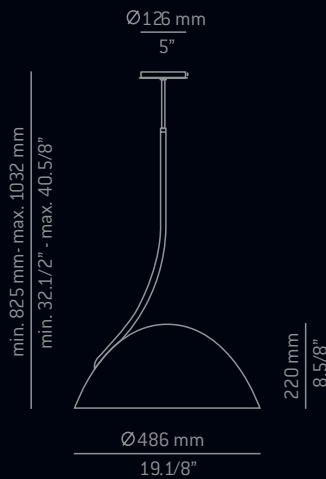

Lámpara de techo metálica con altura regulable. Pantalla de metacrilato. Difusor inferior de metacrilato opcional (kit).

Metallic pendant with adjustable height. Methacrylate lampshade. Bottom methacrylate diffuser kit optional.



Metallpendel. Kunststoffschild. Höhenverstellbar. Optional untere Kunststoffabdeckung.



Suspension en métal. Abat-jour en méthacrylate. Hauteur réglable. Méthacrylate diffuseur inférieur optionnel.

●● 22CR 26NE 74BL

Pantalla Shade Schirm Abat-jour

● 27BL 64NE B

EI. Fluor. | Ø 120mm | E27 | 20W | 230V |  

EI. Fluor. | E27 | 30W | 230V |  ES 

Incan. | E27 | 100W | 230V 





# lungta T-3075

estudi alfred garcía gotós

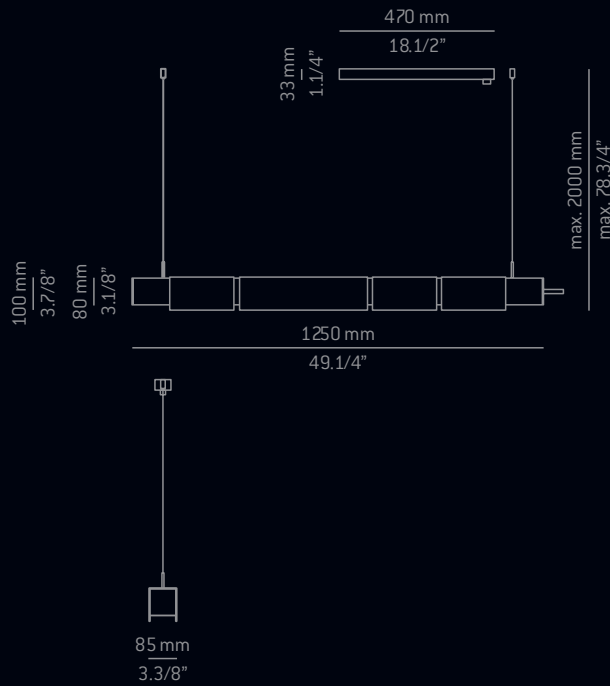



Lámpara de techo con luz directa e indirecta. Pantalla de policarbonato blanco satinado con piezas decorativas de metacrilato serigrafiado o de color blanco opal. Altura e intensidad regulables.

Pendant providing direct and indirect light. Shade is made of satinated polycarbonate and decorative metacrylate trims with serigraphy or opal white color. Adjustable height and dimmable intensity.

Pendelleuchte. Direktes und indirektes Licht. Satinierter Polycarbonatschirm und dekorative Kunststoffelemente mit Serigrafie oder in opalweiß. Höhenverstellbar. Dimmbares. Vorschaltgerät.

Suspension lumière directe et indirecte Abat-jour en polycarbonate blanc satiné et éléments décoratifs en méthacrylate avec ou sans sérigraphie. Hauteur réglable. Ballast dimmable.

● 74BL

El. Fluorescent I T5 I 2X54W  ES 

   

## t-2600 | t-2601

## t-2601F | t-2602

## t-2602F

estudi estiluz

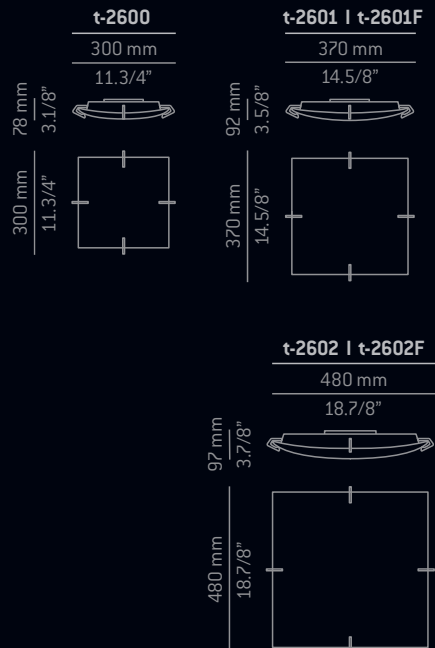

Plafón. Vidrio óptico blanco satinado.

Flushmount. White satin glass. "Tool-less" entry for relamping.

Deckenleuchte. Glas weiß satiniert.

Plafonnier. Verre blanc satiné.

● 22CR (t-2600)

● 37NI (t-2600 | t-2601 | t-2601F | t-2602 | t-2602F)



### t-2600

Hal. I R7s I 118mm I ECO 130W I 230V 

### t-2601

Hal. I R7s I 118mm I ECO 200W I 230V 



### t-2601F

El. Fluorescent I G24q3 I 2x26W  ES 

### t-2602

Hal. I R7s I 118mm I ECO 200W I 230V 

### t-2602F

El. Fluorescent I G24q3 I 2x26W  ES 

## shadow T-2935

jordi vayreda

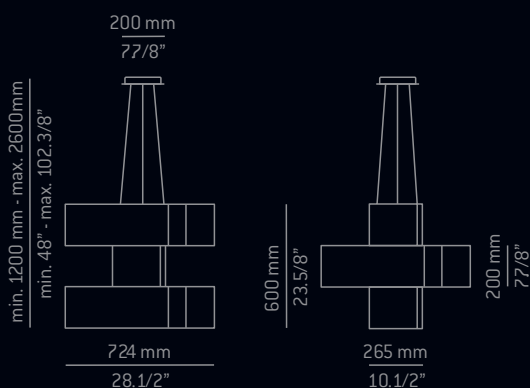

Lámpara de techo metálica con difusor de policarbonato en la parte inferior. Apta para uso exterior.

Metallic pendant with polycarbonate diffuser on the bottom. It can also be installed outdoor.

Metallpendel. Unterer Polycarbonatdiffusor. Für außen geeignet.

Suspension en métal avec diffuseur inférieur en polycarbonate. Apte pour extérieur.

● 76BL M 88AN

El. fluorescent | 2G11 | 2x55W  
universal voltage ballast



## nan A-3040X

guimeràicnca

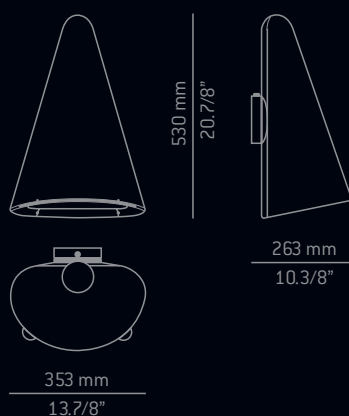

Aplique con luz directa e indirecta. Pantalla de polietileno satinado (material traslúcido). Apto para uso exterior.

Wall sconce providing direct and indirect light. Shade is made of satinated polyethylene (translucent). Outdoor.

Wandleuchte. Direktes und indirektes Licht. Satinierter Polyethylenschirm (durchscheinend). Für außen geeignet.

Applique lumière directe et indirecte. Abat-jour en polyéthylène blanc satiné (matériel translucide). Apte pour extérieur.

● 79BL SAT

El. Fluorescent | E27 | 30W | 230V

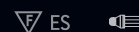

## nan M-3044X

guimeràicina

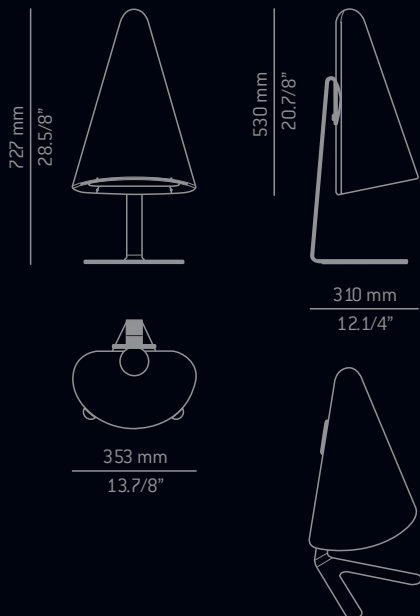



Lámpara de pie baja con luz directa e indirecta. Pantalla de polietileno satinado (material traslúcido). Apto para uso exterior.

Short floor lamp providing direct and indirect light. Shade is made of satinated polyethylene (translucent). Outdoor.

Kleine Stehleuchte. Direktes und indirektes Licht. Sati-nierter Polyethylenschirm (durchscheinend). Für außen geeignet.

Lampe à poser lumière directe et indirecte. Abat-jour en polyéthylène blanc satiné (matériel translucide). Apte pour extérieur.

### ● 79BL SAT

El. Fluorescent | E27 | 30W | 230V  ES 

## dot t-2902X

serra&delarocha



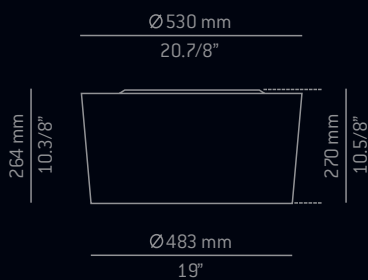

Plafón con luz directa e indirecta. Pantalla de polietileno satinado (material traslúcido). Apto para uso exterior.

Flushmount providing direct and indirect light. Shade is made of satinated polyethylene (translucent). Outdoor.

Decken-/Wandleuchte. Direktes und indirektes Licht. Polyethylenschirm satiniert (durchscheinend). Für außen geeignet.

Plafonnier lumière directe et indirecte. Abat-jour en polyéthylène blanc satiné (matériel translucide). Apte pour extérieur.

### ● 79BL SAT

El. Fluorescent | E27 | 2X30W | 230V  ES 

## dot M-2907X

serra&delarocha



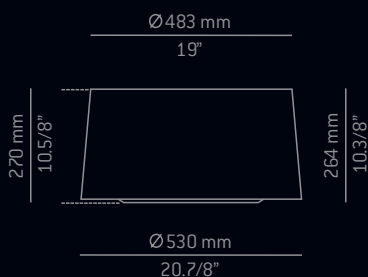

Mesa de polietileno satinado (material traslúcido) con luz directa e indirecta y superficie de metacrilato negro. Apto para uso exterior.

Table made of satinated polyethylene (translucent) providing direct and indirect light with a top methacrylate surface. Outdoor.

Tischleuchte aus satiniertem Polyethylen (durchscheinendes Material). Direktes und indirektes Licht. Obere schwarze Kunststoffplatte. Für außen geeignet.

Table basse en polyéthylène satiné translucide, lumière directe - indirecte, plateau en méthacrylate noir. Apte pour extérieur.

### ● 79BL SAT

El. Fluorescent | E27 | 2X30W | 230V  ES 

## dot P-2909 | P-2909X

serra&delarocha



Lámpara de pie con luz directa e indirecta. Pantalla de polietileno satinado (material traslúcido).

Floor lamp providing direct and indirect light. Shade is made of satinated polyethylene (translucent). P-2909X is suitable for outdoor use.



Metallstehleuchte. Direktes und indirektes Licht. Polyethylenschirm satiniert (durchscheinend).

Lampadaire lumière directe et indirecte en métal avec abat-jour en polyéthylène blanc satiné (matériel translucide).



### ● 76BL M (P-2909)

### ● 79BL SAT (P-2909X)

#### P-2909

El. Fluorescent | E27 | 2X30W | 230V  ES  

#### P-2909X

El. Fluorescent | E27 | 2X30W | 230V  ES  

# dot T-2905 | T-2905X

serra&delarocha

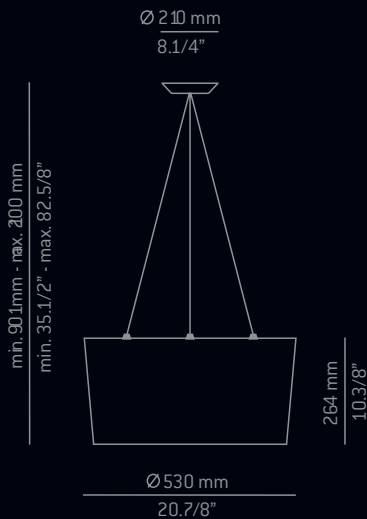

Lámpara de techo con luz directa e indirecta. Pantalla de polietileno satinado (material traslúcido). Altura regulable. T-2905X es apta para uso exterior.

Pendant providing direct and indirect light. Shade is made of satinated polyethylene (translucent). Adjustable height. T-2905X is suitable for outdoor use.

Pendelleuchte. Direktes und indirektes Licht. Polyethylenschirm satiniert (durchscheinend). Höhenverstellbar. Für außen geeignet (T-2905X).

Suspension lumière directe et indirecte avec abat-jour en polyéthylène blanc satiné (matériel translucide). Hauteur réglable. (Version T-2905X pour extérieur).

- 76BL M (T-2905)
- 79BL SAT (T-2905X)

## P-2905

El. Fluorescent | E27 | 2X30W | 230V

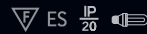

## P-2905X

El. Fluorescent | E27 | 2X30W | 230V

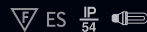

## acabados

finishes | oberflächen | finitions

- 20AL  
Aluminio | Aluminum | Aluminium | Aluminium
- 22CR  
Cromo | Polished chrome | Chrom | Chromé
- 26NE  
Lacado negro | Black lacquer | Mattschwarz lackiert | Laqué noir
- 37NI  
Níquel | Brushed Nickel | Nickel gebürstet | Nickel satiné
- 74BL  
Lacado blanco brillante | White lacquer | Weiß glänzend lackiert  
Laqué blanc brillant
- 76BL M  
Blanco mate (rugoso) | Matt white (rough) | mattweiß (rau)  
Blancmat (rugueux)
- 79BL SAT  
Blanco satinado | White satin | Weiß karat | Blanc satiné
- 88AN  
Arena | Sand | Sand | Sablet

## pantalla

shade | schirm | abat-jour

- 27BL  
Blanco | White | Weiß | Blanc
- 64N BR  
Negro brillante | Shiny black  
Schwarz glänzend | Noir Brillant

ES\*

nueva bombilla de Economía de Energía | new Energy Saving bulb | nouvelle ampoule Economie d'énergie  
neues energiesparendes Leuchtmittel







**estiluz**®

**ESTILUZ, S.A.** (Grupo Estiluz)  
Carretera d'Ogassa s/n  
E-17860 St Joan de les Abadesses  
(Girona) Spain  
T +34 972 720 125  
F +34 972 720 796  
estiluz@estiluz.com  
www.estiluz.com

**DEKA DISTRIBUTION Sarl**  
(Grupo Estiluz)  
2bis, rue Léon Blum. Z.I. des Glaises  
91124 Palaiseau cédex  
France  
T +33 (0) 1 69 32 03 90  
F +33 (0) 1 69 32 02 78  
estiluzfr@estiluz.com

**ESTILUZ GmbH**  
(Grupo Estiluz)  
Pfungstweidstraße 5  
D-60316 Frankfurt am Main  
Deutschland  
T +49 (0) 69 42 69 30 0  
F +49 (0) 69 42 69 30 20  
estiluzgmbh@estiluz.com