

LUCENTE<sup>®</sup>

2011COLLECTION

**LUCENTE®**  
2011COLLECTION



LUCENTE parla di luce attraverso le sue collezioni che esprimono idee forti e che possiedono una personalità speciale. Le idee diventano materia anche attraverso la collaborazione con personalità diverse dal mondo del design, interpretando il pensiero di grandi professionisti e restituendo progetti che dimostrano tutta l'intuizione trasformata in semplicità.

LUCENTE è una combinazione di eleganza, di forme organiche e funzionalità, un progetto nato sulla convinzione che gli oggetti con un buon design possano migliorare la qualità della vita grazie alla loro estetica funzionale. La luce è capace di cambiare atmosfere e stati d'animo, Lucente cerca di interpretarne le sue molteplici applicazioni nella vita quotidiana.

# DESIGNERS



AFRA E TOBIA  
SCARPA



CARLO  
FORCOLINI



ALESSANDRO  
MENDINI



DODO  
ARSLAN

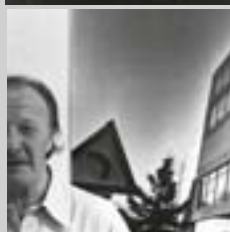

GIANDOMENICO  
BELOTTI



PAOLO  
DE LUCCHI



ROBERTO  
FAVARETTO



SANDRO  
SANTANTONIO  
DESIGN



MARTEN CLAESSON,  
EERO KOIVISTO,  
OLA RUNE



SIMONE  
DERAI



NORWAY  
SAYS



THOMAS  
SANDELL



BRIAN  
RASMUSSEN



MARIO  
MAZZER

LUCENTE talks about light through its collections which express strong ideas and have a special personality. Ideas become matter through collaboration with different personalities from the design world, interpreting the thought of great professionals and coming up with projects that demonstrate how intuition can be transformed into simplicity.

LUCENTE is a combination of elegance, organic shapes and functionality, a project springing from the conviction that well-designed objects can improve the quality of life thanks to their functional aesthetic appearance. The light is able to change atmospheres and moods, Lucente tries to interpret its many applications in everyday life.

# INDICE

AERO 82		CU-BIC 54		FLAT-R 214	
AGAVE 240		CYCLOS 70		FLORA 252	
AIN 278		DECO' 96		FLY 136	
ARUM 28		ECLIPSE 60		GRIFO 182	
BANALE 102		ECO 282		HAPPY 284	
BLUES 264		EIGHT 176		INTERNOS 202	
BRICK 276		EIGHT 1000 180		JAZZ 260	
CLETO 268		EQUAL 226		KALYPSO 42	
CLIVIA 36		FLAT-Q 220		LOLLYPOP 90	

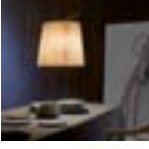
MAI 64		RIVER 164		UP 14	
MAX 192		SAO 174		VISION 236	
MAX-H 186		SEMJASE 22		VITA 08	
NIPPO 244		SPACE 256		WAY 126	
NOA 116		SPOOL 158		WEDGE 46	
NURA 108		STYLE 132		ZEN 230	
PINKO 152		TAMBURO 206		ZERO 226	
PROJECT 03 140		TARA 170			
REMEMBER 146		TRATTO 272			



# VITA

design Brian Rasmussen 2011

**Sospensione a luce diffusa composta da 19 elementi in metallo che richiamano la forma elicoidale e che, dal centro della lampada dove si trova la sorgente luminosa, si irradiano verso l'esterno. La loro composizione appare geometrica e ordinata, da certi punti di vista, dinamica e casuale da altri. La fonte luminosa è al centro, contenuta all'interno di un vetro soffiato opale. Disponibile nei colori verniciato bianco lucido e rosso.**

Diffused light pendant made up of 19 metal coils spreading out from the globe with the lamp in the centre outward. The design is neat and geometrical at the same time looking vibrant and random. The lamp is inside the opal blown glass in the centre. Available finishes: glossy white and red painted.

Suspension à lumière diffuse composée de 19 formes hélicoïdales en métal. Un globe en verre est situé au centre, duquel partent ces formes géométrique à la fois dynamique et aléatoires. Le globe au centre est en verre soufflé opalin. Disponible en blanc ou rouge brillant.

Hängeleuchte mit diffusem Licht. Die Struktur besteht aus 19 Metallelementen, die eine Spirale bilden und von der Mitte der Leuchte aus, wo sich die Lichtquelle befindet, nach außen strahlen. Ihre Anordnung wirkt aus manchen Blickwinkeln geometrisch und geordnet, aus anderen dynamisch und zufällig. Die Lichtquelle befindet sich in geblasenem Opalglas. Oberfläche: Weiße oder rote Lackierung.

Lámpara suspendida a luz difusa con 19 elementos de metal de forma helicoidal que dal centro van estendendose hacia l'exterior. La composición de los elementos es geométrica y ordenada y nel mismo tiempo dinámica y casual. La bombilla está al centro dentro un vidrio soplado mate. Disponible en los colores blanco brillo y rojo.

Подвесной светильник состоит из 19-ти спиралевидных металлических элементов и центральной части, где расположен источник света. Спирали соединены в центре светильника и, расширяясь, расходятся наружу, создавая шарообразную форму. Спирали создают оригинальную композицию, которая с разных точек зрения кажется либо геометрически выверенной, либо хаотически разбросанной. Источник света заключен в шар из матового дутого стекла и располагается в середине светильника. Спирали могут быть окрашены в блестящий белый или красный цвет.

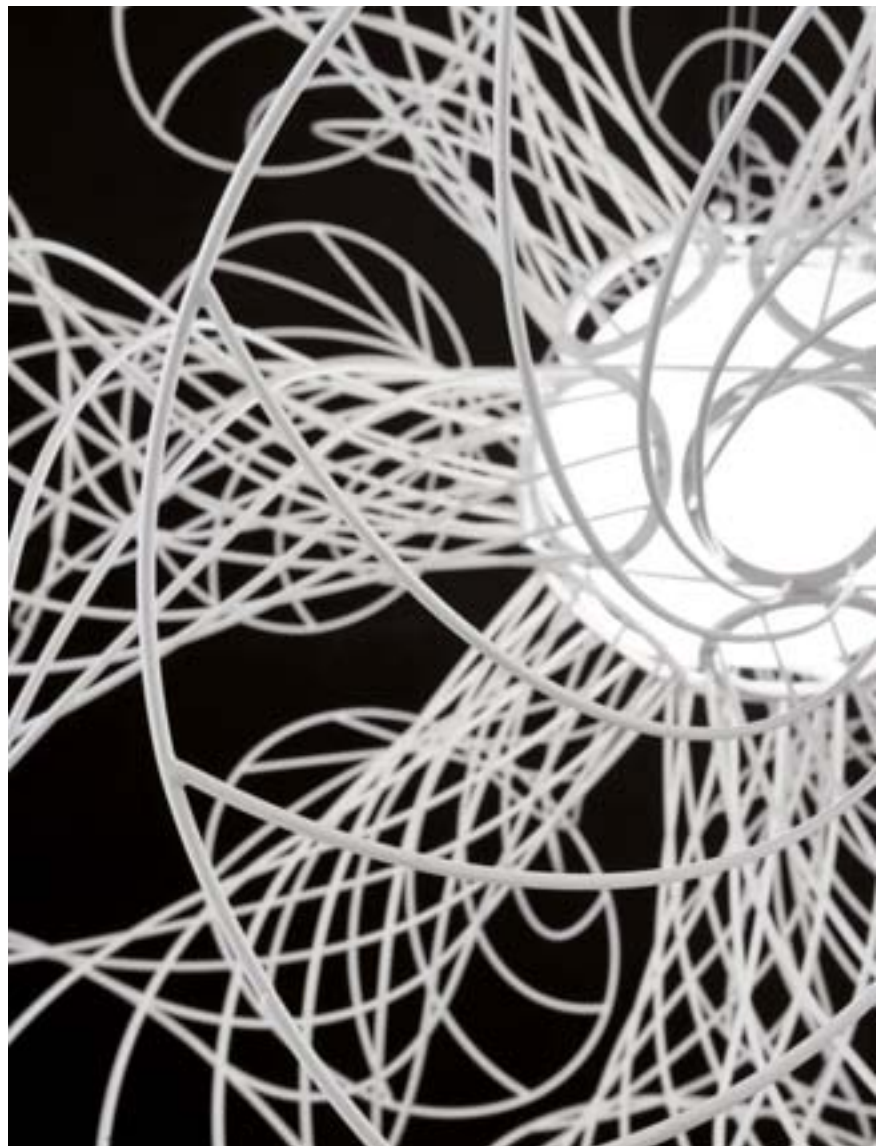

**Bianco lucido**  
Glossy white



**Rosso lucido**  
Glossy red

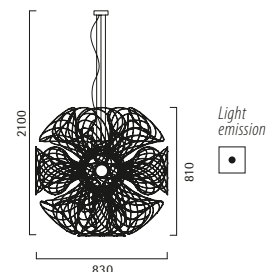





Lampada sospensione - *Pendant lamp*

**013175** Bianco lucido - *Glossy white*

**013176** Rosso lucido - *Glossy red*

E27 1x105W A55 

E27 1x100W QT-32 

  



# VITA

design Brian Rasmussen 2011

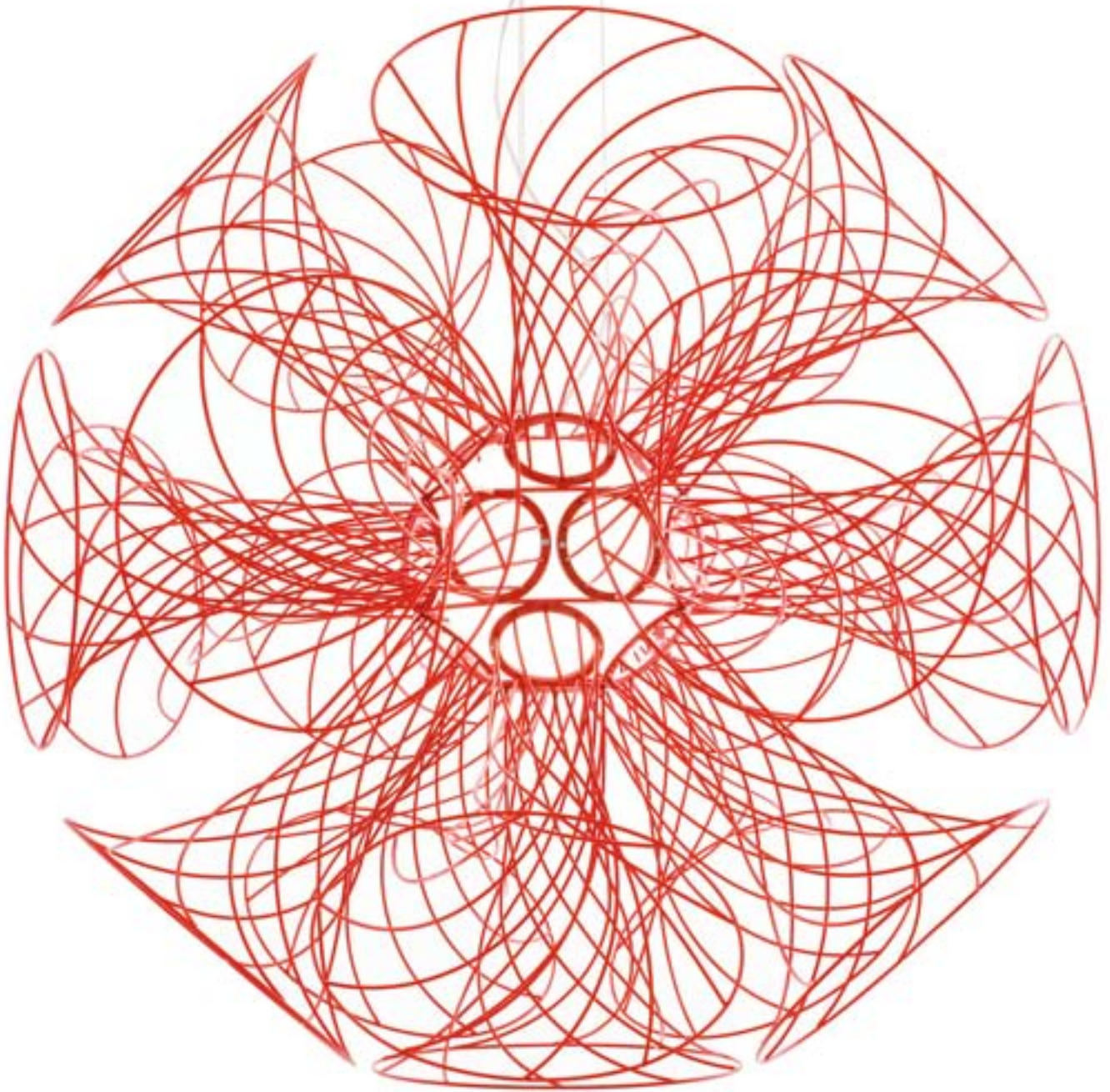

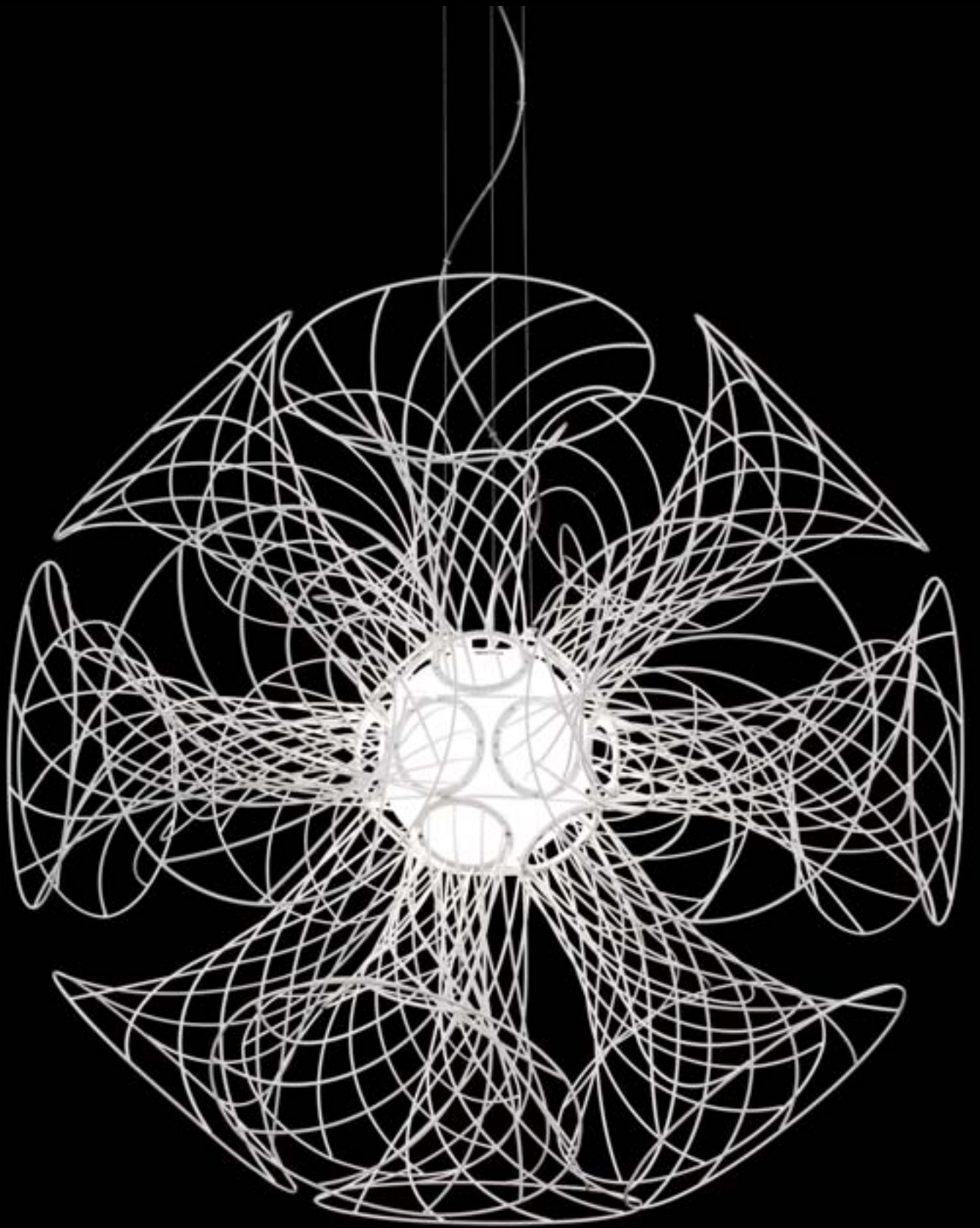

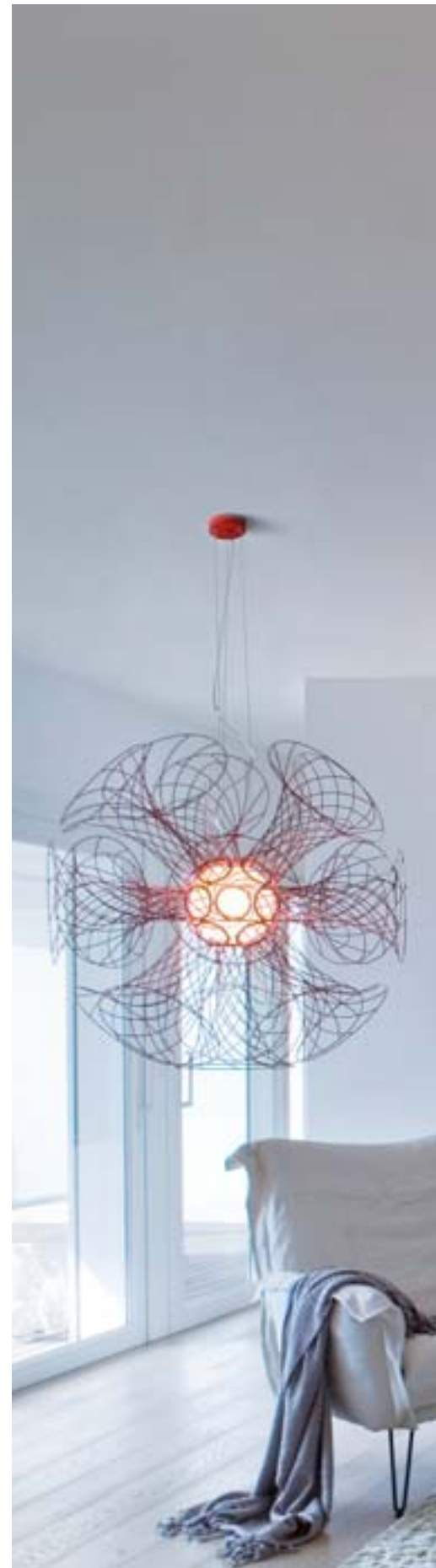
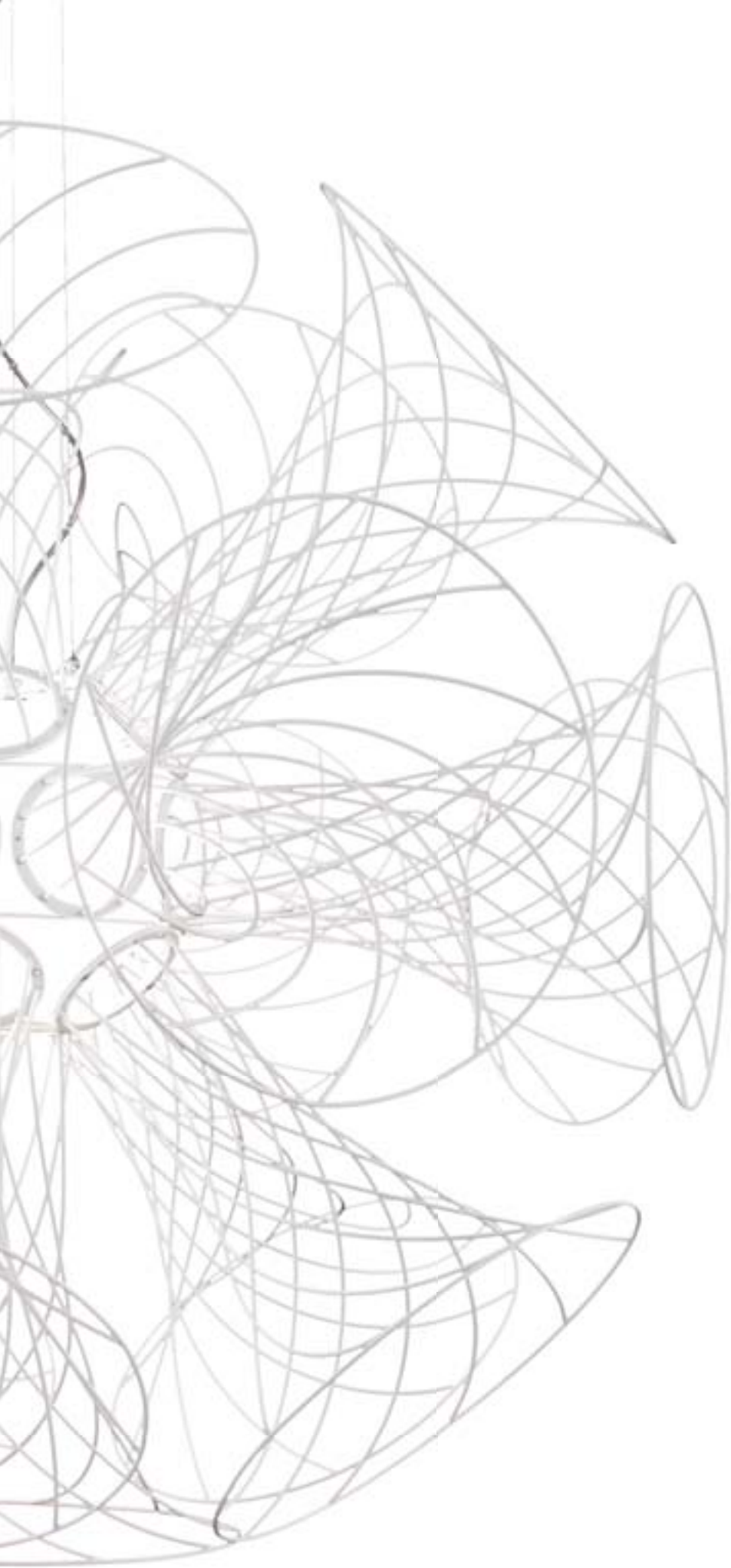

# VITA

design Brian Rasmussen 2011



UP

design Mario Mazzer 2011

Lampada da terra realizzata in polietilene colore avorio tramite la tecnologia dello stampaggio rotazionale. La lampada è disponibile sia nella versione da interno che da esterno (IP44). Nella versione da interno sono disponibili degli accessori in lana lavorata a coste nei colori beige oppure rosso, da mettere come rivestimento al paralume. Nella versione da interno la base e il paralume possono avere un'accensione separata e dimerabile.

Ivory polyethylene floor lamp made with the rotational moulding technology. Available for indoor and outdoor (IP44) application. On the indoor version a wool cover for the diffuser is available in cream and red. On the indoor version the stem and the diffuser have separate dimmable switches.

Lampadaire en polyéthylène, coloris ivoire, réalisé grâce à une technique de moulage rotatif. Disponible pour intérieur ou extérieur (IP44). Pour le modèle d'intérieur, une étoffe de laine est disponible pour être rajouté à l'abat-jour, de couleur rouge ou crème. Pour la version d'intérieur, l'allumage peut être séparé est composé de deux variateurs, l'un pour le corps et le second pour l'abat-jour.

UP ist eine große Bodenleuchte für den Innen- und Außenbereich (Version IP44), die im Rotoformverfahren vollständig aus Polyäthylen gefertigt wurde. Die Basis und der Lampenschirm können gleichzeitig oder getrennt voneinander beleuchtet werden. Die Lampe ist in Elfenbeinweiß erhältlich. Bei der Version für den Innenbereich ist als Überzug des Lampenschirms ein beige oder rotes geripptes Wollteil mit einem Durchmesser von 60 Zentimetern erhältlich.

Lámpara de pie hecho en polietilene color marfil con la técnica del moldeo rotacional. La lámpara es disponible en la versión para interior o en la versión para exterior (IP44). En la versión para interior son disponibles accesorios en lana rojo o beige como decoración por la pantalla. Para la versión de interiores la base y la pantalla pueden iluminarse de forma independiente y regulable.

Корпус этого напольного светильника изготовлен из полиэтилена цвета слоновой кости методом ротационного формования. Светильник может быть как внутренним, так и уличным (IP44). Для внутренней модели предлагаются дополнительные вязанные из шерсти аксессуары бежевого или красного цвета. Их можно надевать на верхнюю, цилиндрическую часть светильника, имеющую диаметр 60 см. У внутренних светильников конусообразное тело и цилиндрический верх могут диммироваться и иметь раздельное включение.

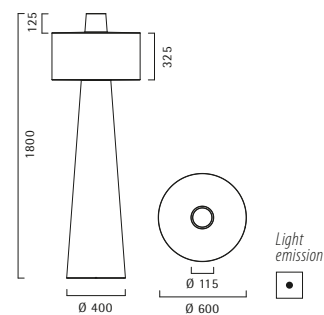

**Avorio**  
Ivory

**Accessorio in lana per versione da interno**  
Wool accessory for indoor version



**022102**  
Beige - Cream

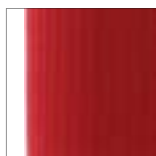

**022103**  
Rosso - Red

**Versione da interno IP20. Accensione separata per base e diffusore. Dimmer per diffusore.**  
Indoor IP20 - Separate switches for base and diffuser. Dimmer for the diffuser light.

Lampada da terra - Floor lamp

**012029** Avorio - Ivory

Base - Base light E27 4x17W TC-TSE ton.825

Diffusore - Diffuser light E27 1x150W QT-32

**CE**

**Versione da interno IP20 DALI. Accensione separata per base e diffusore. Dimmer per base (DALI) e diffusore.**  
Indoor IP20 DALI - Separate switches for base and diffuser. Dimmer for the base (DALI) and the diffuser light.

Lampada da terra - Floor lamp

**012030** Avorio - Ivory

Base - Base light G5 2x28W T5 ton.827

Diffusore - Diffuser light E27 1x150W QT-32

**CE**





UP

design Mario Mazzer 2011





UP

design Mario Mazzer 2011





UP IP44  
design Mario Mazzer 2011

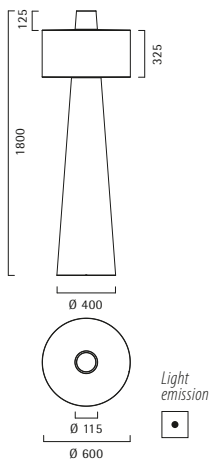

Versione da esterno IP44 - on/off

Outdoor IP44 - on/off

Lampada da terra - Floor lamp

012028 Avorio - Ivory

Base - Base light E27 4x17W TC-TSE ton.825 

Diffusore - Diffuser light E27 1x30W TC-TSE ton.825 

E27 1x150W QT-32 



Avorio  
Ivory





# SEMJASE

design Sandro Santantonio Design 2010

**Lampada da terra in poliuretano espanso strutturale stampato a iniezione. Finitura verniciato bianco lucido con particolare della base in grigio lucido.**

Injection-moulded foam polyurethane. Glossy white painted with glossy grey detail on the base.

Lampadaire en polyuréthane expansé structurel procédé par injection. Finition verni blanc brillant avec les détails de la base en gris brillant.

Stehleuchte in Polyurethan Schaumstoff gepresst mit strukturierter Oberfläche in weiss glänzend und als Besonderheit ein grau glänzender Fuß.

Lampara de pie en poliuretano expandido estructural estampado a inyección. Acabado barnizado blanco brillo con base en gris brillo.

Белый глянцевый корпус выполнен из полиуретана с серыми деталями на базе.

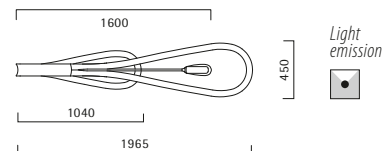
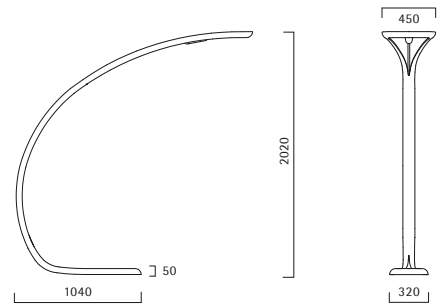

**Bianco lucido**  
Glossy white



Lampada da terra - Floor lamp  
Bianco - White

**007720**

R7s 118mm 1x230W QT-DE 







# SEMJASE

design Sandro Santantonio Design 2010

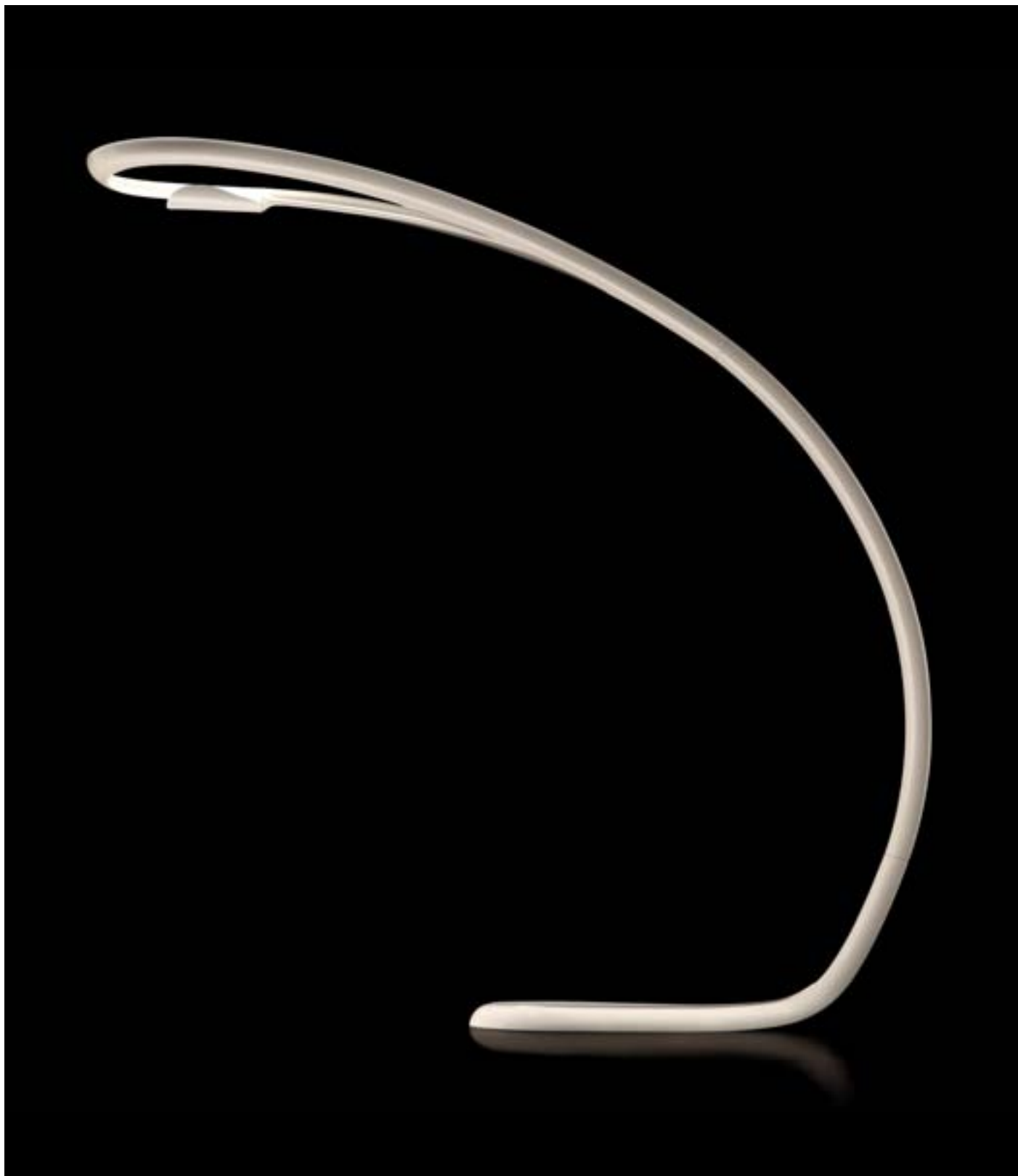



# SEMJASE

design Sandro Santantonio Design 2010



# ARUM

design Sandro Santantonio Design 2009

**Lampada da terra con struttura metallica verniciata bianca opaca e rivestimento in tessuto elasticizzato sfoderabile e lavabile. Tessuto disponibile nei colori avorio oppure rosso.**

Floor lamp. Mat white metal structure, removable and washable stretch-fabric available in ivory and red.

Lampe de terre avec structure blanche opaque vernie métallique et revêtement en tissu élastique amovible et lavable.  
Tissu disponible en ivoire ou rouge.

Stehleuchte mit Metalstruktur in weiss matt lackiert und mit einem waschbaren und austauschbarem elastischem Gewebe ummantelt. Das Gewebe ist in den Farben elfenbein und rot erhältlich.

Lámpara de pie. Estructura metálica barnizada blanca revestida de tejido elástico y lavable. Tejido disponible en los colores marfil y rojo.

Торшер. Матовое белое металлическое основание, ткань красного или песочного цвета, которую можно снять и постирать по необходимости.

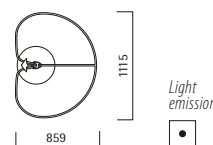
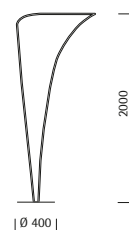

Lampada da terra - Floor lamp

**017770** Avorio - Ivory

**017771** Rosso - Red

Superiore - Top E27 1x205W QT-32

Inferiore - Bottom GU10 1x50W QPAR



# ARUM

design Sandro Santantonio Design 2009









# ARUM

design Sandro Santantonio Design 2009





# ARUM

design Sandro Santantonio Design 2009



Lampada da parete dal design minimalista ed elegante, con una vocazione per la sostenibilità: la luce è indiretta e prodotta da una fonte luminosa a led da 8,4W disponibile sia a luce calda che fredda. La parte frontale è in alluminio verniciato bianco opaco sovrapposta ad una parte in plexiglas trasparente lucido che conduce lievemente la luce. Alimentatore incluso.

Wall light featuring a minimalist and refined design and highly sustainable. Indirect light. 8,4W LED both cold and warm. Matt white painted metal front with transparent Perspex behind for indirect light emission. Ballast included.

Applique murale avec un design raffiné et minimaliste. Eclairage indirect de 8,4W led avec une lumière chaude ou froide sur demande. La partie frontale est en aluminium mat blanc avec une partie à l'arrière en plexi transparent et conducteur de lumière. Alimentation incluse.

Leuchte in minimalistischem und elegantem Design, umweltbewusst entwickelt: das indirekte Licht wird von einer 8,4 W-LED-Lampe erzeugt, die einen sparsamen Energieverbrauch sicherstellt. Die LED-Lampe ist sowohl mit warmem oder kühlem Licht erhältlich. Die Front besteht aus mattweiß lackiertem Aluminium, das auf einer Seite von glänzend transparentem und leicht lichtleitendem Plexiglas bedeckt ist. Der Konverter ist inklusive.

Lámpara de pared dal diseño mínimo e elegante, con vocación sostenible: luz indirecta producida por Led de 8.4W, disponibe con luz de tonalidad blanco natural y blanco cálido. Estructura frontal en aluminio barnizado blanco mate con plexiglás transparente brillo que difunde la luz lateralmente. Alimentador incluido.

Настенный светильник с минималистическим и элегантным дизайном, создает отраженный свет. LED 8,4W может быть как теплым, так холодным. Корпус выполнен из алюминия и окрашен в белый матовый цвет. Рассеиватель из прозрачного плексигласа.



Bianco opaco  
Matt white

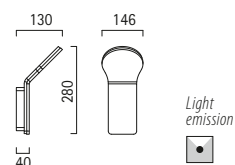

Lampada da parete - Wall lamp  
Bianco opaco - Matt white

**015610** LED 8,4W 3.000°K 220-240V

**015611** LED 8,4W 4.100°K 220-240V

CE IP 20









CLIVIA





# KALYPSO IP44

design Paolo De Lucchi 2010

**Serie in alluminio pressofuso, finitura cromo. La lampada da parete è dotata di braccio flessibile cromato orientabile a 360°. Alimentatore incluso. Grado di protezione IP44. Illuminazione Led 3,6W 220-240V 50-60Hz tonalità Natural White 4100°K e Warm White 3000°K.**

Chrome die cast aluminium lamps. The wall lamp is provided with a chrome swing 360° arm. Ballast included. IP44 rated. 3,6W LED. 220-240V 50-60Hz Natural White 4100°K and Warm White 3000°K.

Séries en fonte d'aluminium finition chrome. L'applique est dotée d'un bras flexible chromé orientable à 360°.

Alimentation incluse. Protection IP44. Source led 3.6W 220-240V 50-60Hz – Température Blanc naturel 4100°K et blanc chaud 3000°K.

Serie aus verchromten Alu-Pressprofil. Die Wandleuchte ist mit einem verchromten, 360° schwenkbaren Arm bestückt. Der Konverter ist inklusive. Schutzart IP 44. Bestückung: LED 3,6W 220-240V 50-60 Hz in Lichtfarbe NW 4100°K und in WW 3000°K.

Serie realizada en aluminio vaciado por presión, acabado cromo. La Lámpara de pared está dotada de un brazo flexible cromado y orientable a 360°. Alimentador incluido. Grado de protección IP44. Iluminación Led 3,6W 220-240V 50-60Hz tonalidad Blanco Natural 4100°K y blanco cálido 3000°K.

Хромированные литые алюминиевые светильники с возможностью направления светового потока в любую сторону. IP44. LED 4100°K белый цвет, 3000°K. Балласт в комплекте.

**Cromo**  
Chrome

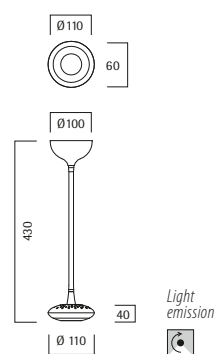

Lampada da parete/soffitto - Wall/ceiling lamp  
Cromo - Chrome

**015601** LED 3,6W 4.100°K 220-240V  
**015602** LED 3,6W 3.000°K 220-240V

CE

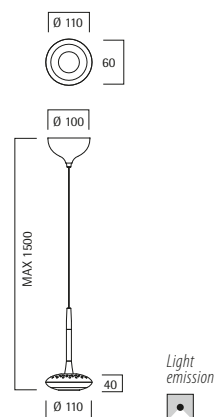

Lampada sospensione - Pendant lamp  
Cromo - Chrome

**015600** LED 3,6W 4.100°K 220-240V  
**015604** LED 3,6W 3.000°K 220-240V

CE



KALYPSO IP44  
design Paolo De Lucchi 2010





# WEDGE

design Paolo De Lucchi 2008

## Lampada orientabile in cristallo pressato. Finiture in cromo.

Adjustable lamps. Clear pressed crystal glass. Chrome finishing.

Structure orientable en métal laqué.  
Difuseur en verre crystal pressé.

Drehbar Struktur aus lackiertem Metall.  
Chrystal glas.

Lámpara orientable en cristal  
prensado. Acabados en cromo.

Прозрачное стекло.  
Хромовое покрытие.

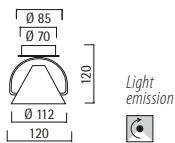

Lampada da parete - Wall lamp  
Cromo - Chrome

**015700**

GU10 1x75W QPAR

CE, ENEC, IP20, PSE

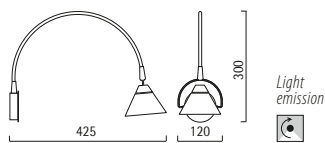

Lampada da parete - Wall lamp  
Cromo - Chrome

**015702**

GU10 1x75W QPAR

CE, ENEC, IP20, PSE

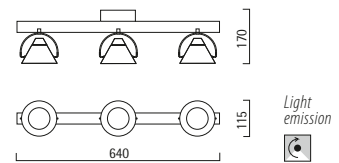

Lampada da parete / soffitto - Ceiling / Wall lamp  
Cromo/Alluminio anodizzato - Chrome/Anodized aluminium

**015704**

GU10 3x75W QPAR

CE, ENEC, IP20, PSE

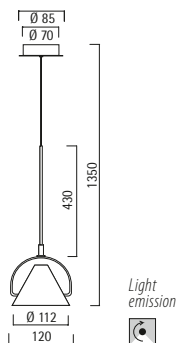

Lampada sospensione - Pendant lamp  
Cromo - Chrome

**015701**

GU10 1x75W QPAR

CE, ENEC, IP20, PSE

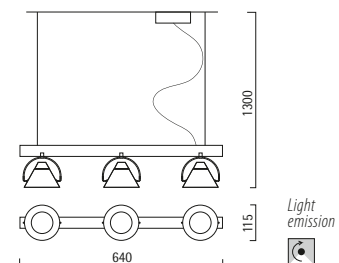

Lampada sospensione - Pendant lamp  
Cromo/Alluminio anodizzato - Chrome/Anodized aluminium

**015703**

GU10 3x75W QPAR

CE, ENEC, IP20, PSE

**Cromo**  
Chrome









WEDGE  
design Paolo De Lucchi 2008







# WEDGE

design Paolo De Lucchi 2008





# CU-BIC IP44 design Lucente Lab

**Struttura in metallo verniciato bianco opaco  
oppure anodizzato spazzolato.  
Vetro di protezione serigrafato nero.  
Grado di protezione IP44 nelle versioni a  
parete. Solo per installazioni interne.**

Metal structure available in mat white  
and anodized brushed aluminium.  
Black painted glass. IP44 rated on the wall version.  
Only for indoor installation.

Structure en métal blanc opaque verni ou anodisé,  
verre de protection sérigraphie noir. Degré de  
protection IP 44 pour la version applique seulement.  
Seulement pour installation intérieures.

Struktur in weiss matt lackiertem oder eloxiertem  
mattem Metall.  
Das Schutzglas ist in schwarz.  
Bei der Wand-Version ist die Schutzart IP44.  
Nur für Installationen im Innenbereich gedacht.

Estructura metálica barnizada blanca o en aluminio  
anodizado cepillado.  
Vidrio serigrafiado negro.  
IP 44 en los modelos da pared.  
Adecuado solo para instalaciones interiores.

Металлическое основание в матовом белом  
и анодированном алюминии.  
Крашеное стекло черного цвета. IP 44.  
олько для внутреннего использования.

**Bianco**  
White



**Alluminio anodizzato spazzolato**  
Anodized brushed aluminium

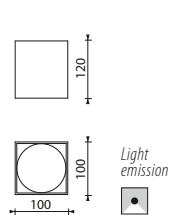

Lampada da parete - Wall lamp - IP 44

**016730** Bianco - White  
**016731** Alluminio - Aluminium  
GU10 1x50W QPAR   
CE

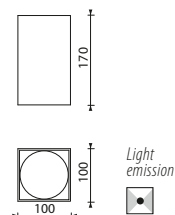

Lampada da parete - Wall lamp - IP 44

**016732** Bianco - White  
**016733** Alluminio - Aluminium  
GU10 2x50W QPAR   
CE

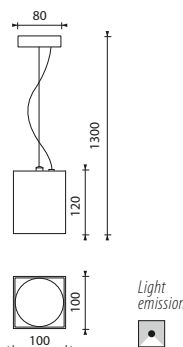

Lampada sospensione - Pendant lamp - IP 20

**016740** Bianco - White  
**016741** Alluminio - Aluminium  
GU10 1x75W QPAR   
CE

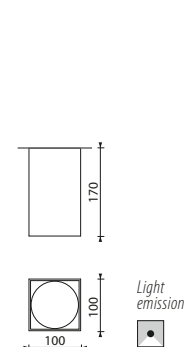

Lampada da soffitto - Ceiling lamp - IP 20

**016736** Bianco - White  
**016737** Alluminio - Aluminium  
GU10 1x75W QPAR   
CE













# ECLIPSE

design Dodo Arslan 2006

Riflettore in metallo verniciato nei colori grigio antracite o bianco.  
Diffusore in vetro soffiato.

Metal painted reflector in grey or white.  
Satin blown opal glass.

Spot frontal en métal verni disponible dans les couleurs gris ou blanc.  
Diffuseur en verre soufflé satiné opale.

Metal Reflektoren, weiß oder grau lackiert.  
Diffusoren aus geblasenem satinierte Glas.

Reflector de metal barnizado gris o blanco.  
Difusor de vidrio soplado opal satinado.

Металлический отражатель серого или белого цветов  
Матовое белое дутое стекло.

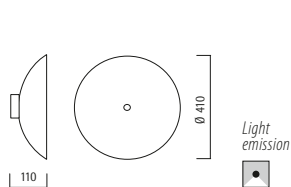

Lampada da soffitto/parete - Ceiling/wall lamp

**017280** Bianco - White

**017281** Grigio - Grey

2GX13 1x55W T5c

alimentazione elettronica - electronic ballast

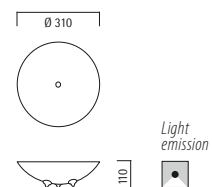

Lampada da tavolo - Table lamp

**017284** Bianco - White

**017285** Grigio - Grey

GX53 1x7W

alimentazione elettronica - electronic ballast







ECLIPSE  
design Dodo Arslan 2006





**Struttura in metallo e parte inferiore chiusa da un disco in metacrilato prismatico trasparente che permette una resa luminosa ottimale. Finiture: verniciato bianco lucido sia all'esterno che all'interno, verniciato bianco lucido all'esterno e arancio lucido all'interno; verniciato rosso metallizzato all'esterno e bianco lucido all'interno. Alimentazione elettronica.**

Metal structure with transparent prismatic acrylic disc underneath for a perfect light emission. Available finishes: glossy white inside and outside, glossy white outside and glossy orange inside, metallic red outside and glossy white inside. Electronic ballast.

Structure en métal avec un disque acrylique transparent prismatique pour une émission de lumière parfaite. Finitions disponibles : blanc brillant intérieur et extérieur ou blanc brillant extérieur orange intérieur ou rouge métallisé extérieur blanc brillant intérieur. Ballast électronique.

Hänge- oder Deckenleuchte mit direktem oder diffusem Licht. Die Metallstruktur wird unten von einer prismatischen, transparenten Methacrylat-Scheibe umschlossen, die für optimale Lichtausbeute sorgt. Farben: Glänzend weiße Lackierung sowohl außen als auch innen. Glänzend weiße Lackierung außen und glänzend orange Lackierung innen. Metallic-rote Lackierung außen und glänzend weiße Lackierung innen. Elektronische Stromversorgung.

Estructura metálica cerrada con un difusor en metacrilato prismático transparente que difunde la luz en manera optimal. Acabados: barnizado externamente e internamente en blanco brillo, barnizado externamente blanco brillo e internamente naranja brillo, barnizado externamente rojo metalizado e internamente blanco brillo. Ballast electrónico.

Металлический корпус закрыт снизу рассеивателем из призматического прозрачного метакрилата, благодаря которому достигается оптимальный световой поток. Корпус может быть окрашен в следующих вариациях: белый блестящий внутри и снаружи; белый блестящий снаружи и оранжевый блестящий внутри; красный металл снаружи и белый блестящий внутри. Имеется встроенный электронный балласт.



**Bianco - Bianco**  
White - White



**Bianco - Arancio**  
White - Orange



**Rosso - Bianco**  
Red - White

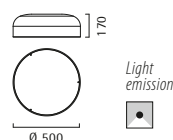

Lampada da soffitto - Ceiling lamp

**012105** Bianco/Bianco - White/White

**012106** Bianco/Arancio - White/Orange

**012107** Rosso/Bianco - Red/White

2GX13 40+22W T5c

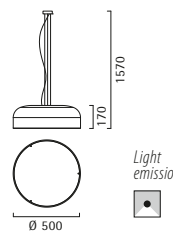

Sospensione - Pendant lamp

**012101** Bianco/Bianco - White/White

**012103** Bianco/Arancio - White/Orange

**012104** Rosso/Bianco - Red/White

2GX13 40+22W T5c









MAI





# CYCLOS

Modello depositato/Patented

design NORWAY SAYS, Torbjørn Anderssen, Andreas Engesvik, Espen Voll 2005

**Corpo esterno in alluminio verniciato a polvere nei colori bianco oppure grigio argento e parte interna diffondente in metacrilato opalino lucido. Alimentazione elettronica.**

Outer body made of white or silver grey powder coated aluminium and inner diffusing body made of glossy opaline methacrylate.  
Electronic ballast.

Corps externe en aluminium laqué à la peinture en poudre dans les coloris blanc ou gris argent et partie interieure diffusante en méthacrylate opalin brillant.  
Ballast électronique.

Externer Leuchtenkörper aus Aluminium, Pulverlackierung in den Farben weiß oder silbergrau, Diffusor innen aus glänzend-opakem Metacrylat.  
Elektronische Stromversorgung.

Cuerpo externo de aluminio barnizado a polvo en color blanco o gris plateado, y parte interior difusora de metacrilato opalino brillante.  
Ballast electrónico.

Белый или серый алюминиевый корпус. Белый глянцевый рассеиватель из метакрилата. Электронный балласт.

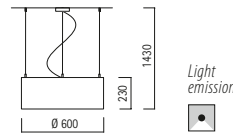

Lampada sospensione - *Pendant lamp*

**012088** Bianco - *White*  
**012087** Grigio argento - *Silver grey*  
G24q-3 5x26W TC-DE   
CE

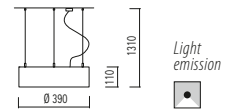

Lampada sospensione - *Pendant lamp*

**012072** Bianco - *White*  
**012073** Grigio argento - *Silver grey*  
2GX13 1x55W T5c   
CE

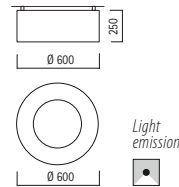

Lampada da soffitto/parete - *Ceiling/wall lamp*

**012069** Bianco - *White*  
**012068** Grigio argento - *Silver grey*  
G24q-3 5x26W TC-DE   
CE

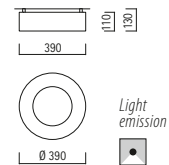

Lampada da soffitto/parete - *Ceiling/wall lamp*

**012070** Bianco - *White*  
**012071** Grigio argento - *Silver grey*  
2GX13 1x55W T5c   
CE

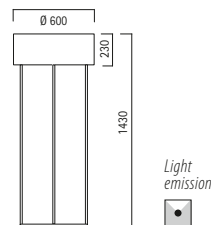

Lampada da terra - *Floor lamp*

**012090** Bianco - *White*  
**012089** Grigio argento - *Silver grey*  
G24q-3 5x26W TC-DE   
CE



Lampada da tavolo - *Table lamp*

**012078** Bianco - *White*  
**012079** Grigio argento - *Silver grey*  
2GX13 1x55W T5c   
CE

**Bianco**  
White



**Grigio argento**  
Silver grey







# CYCLOS

design NORWAY SAYS, Torbjørn Anderssen,  
Andreas Engesvik, Espen Voll 2005







# CYCLOS

design NORWAY SAYS, Torbjørn Andersen,  
Andreas Engesvik, Espen Voll 2005





# CYCLOS

design NORWAY SAYS, Torbjørn Anderssen,  
Andreas Engesvik, Espen Voll 2005



# CYCLOS

design NORWAY SAYS, Torbjørn Anderssen,  
Andreas Engesvik, Espen Voll 2005









# CYCLOS

design NORWAY SAYS, Torbjørn Andersen,  
Andreas Engesvik, Espen Voll 2005



# AERO

design Dodo Arslan 2007

**Struttura in metallo. Vetro soffiato opalino (opalino e incamicciato ambra nella versione sospensione grande) o incamicciato rosso satinato. Nella versione da tavolo, parete e terra opale particolari superiori in vetro a scelta nei colori: rosso, verde, ambra o bianco. Nella versione rosso il particolare è bianco.**

Metal structure. Opal and satin red blown glass diffuser. Amber option for the bigger pendant.

The opal glass table, wall and floor lamps have the upper glass details available in red, green, amber and white. All the models with red glass have white details.

Structure en métal. Verre soufflé opalin (opalino et doublé ambre dans la version grande suspension) ou doublé rouge satiné. Dans la version opale de table, murale et de sol, les détails supérieurs en verre peuvent être selon le choix dans les coloris: rouge, vert, ambre ou blanc. Dans les versions «rouge», le détail est blanc.

Struktur aus Metall. Geblasenem Opalglas. (Opal und mit Bernstein verkleidet in der großen Hängeausführung) bzw. rot verkleidet, matt. Bei der Tisch-, Wand- und Bodenausführung Opale kann für die oberen Details aus Glas unter folgende Farben gewählt werden: Rot, Grün, Bernstein oder Weiß. Bei der Ausführung in Rot ist das Detail weiß.

Estructura de metal. Vidrio soplado opalino (opalino y enfundado ámbar en la suspensión grande) o enfundado rojo satinado. En la versión ópalo para mesa, pared y suelo, los detalles superiores de vidrio se pueden elegir en los siguientes colores: rojo, verde, ámbar o blanco. En la versión en rojo el detalle es blanco.

Металлическое основание. Белое и красное дутое стекло. Плафон белого наружного и песочного внутреннего цветов представлен в подвесных светильниках. Стекланные вставки прочно крепятся на магнитах и представлены в красном, зеленом, песочном и белом цветах.

**Bianco**  
White



**Bianco - Ambra**  
White - Amber



**Rosso - Bianco**  
Red - White



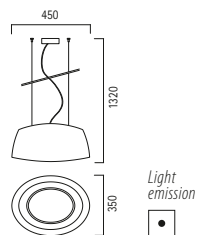

Lampada sospensione - Pendant lamp

Cromo - Chrome

**012662** Rosso - Red

**012668** Bianco - White

**012663** Bianco/Ambra - White/Amber

E27 2x52W A55

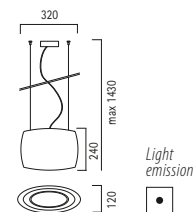

Lampada sospensione - Pendant lamp

Grigio argento - Silver grey

**012660** Rosso - Red

**012661** Bianco - White

E27 1x70W A55

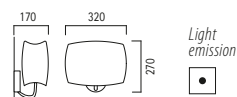

Lampada da parete - Wall lamp

Grigio argento - Silver grey

**012666** Bianco - White

**012667** Rosso - Red

E27 1x70W QT-32

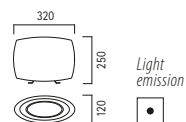

Lampada da tavolo - Table lamp

Grigio argento - Silver grey

**012664** Bianco - White

**012665** Rosso - Red

E27 1x70W QT-32

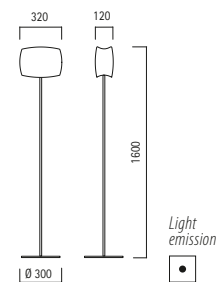

Lampada da terra - Floor lamp

Grigio argento - Silver grey

**012670** Bianco - White

**012671** Rosso - Red

E27 1x70W QT-32

Codice particolare per lampade da tavolo, parete e terra.  
Upper glass code for table, wall and floor lamps.



**060087**  
Bianco - White



**060086**  
Ambra - Amber



**060084**  
Rosso - Red



**060085**  
Verde - Green

# AERO

design Dodo Arslan 2007







# AERO

design Dodo Arslan 2007





# AERO

design Dodo Arslan 2007





# LOLLYPOP

design Sandro Santantonio Design 2007

**Struttura metallica in nickel spazzolato.**  
**Diffusori in vetro pirex satinato.**

Brushed nickel metal structure.  
Satin Pyrex diffusers.

Structure métallique nickel brossée.  
Verre soufflé opalin pyrex.

Struktur aus Nickel gebürstet Metall.  
Diffusoren aus geblasenem satinierte Pyrex Glass.

Estructura metálica en níquel cepillado.  
Difusores de vidrio soplado pirex satinado.

Никелированное металлическое основание.  
Матовое жаростойкое стекло.

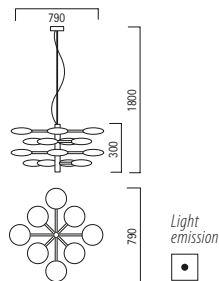

Lampada sospensione - *Pendant lamp*  
Nickel spazzolato - *Brushed nickel*

**014510**

G9 16x20W QT-13

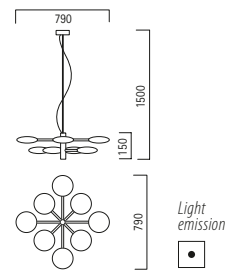

Lampada sospensione - *Pendant lamp*  
Nickel spazzolato - *Brushed nickel*

**014511**

G9 8x33W QT-13

**Bianco**  
White



**Nickel spazzolato**  
Brushed nickel

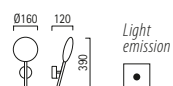

Lampada da parete - *Wall lamp*  
Nickel spazzolato - *Brushed nickel*

**014513**

G9 1x48W QT-13

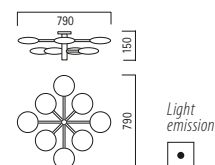

Lampada da soffitto/parete - *Ceiling/wall lamp*  
Nickel spazzolato - *Brushed nickel*

**014512**

G9 8x33W QT-13





# LOLLYPOP

design Sandro Santantonio Design 2007





# LOLLYPOP

design Sandro Santantonio Design 2007





**Diffusore in vetro soffiato con finitura lucida, disponibile nei colori bianco oppure ambra e con finitura opaca nei colori verde-sabbia oppure rosso-sabbia. Struttura in metallo cromato.**

Blown glass diffuser available in glossy white and amber. Also available in matt sandy-green and sandy-red. Metal structure in chrome.

Diffuseur en verre soufflé, finition brillante disponible en blanc ou ambre mais aussi sablonneux verre ou sablonneux rouge. Structure en métal laqué.

Diffusor in geblasenem Glas in glänzender Ausführung, in den Farben weiss oder amber und als mattierte version in gruen-grau oder in sandrot erhältlich. Struktur aus lackiertem Metall.

Difusores en vidrio soplado en los colores blanco brillante, ámbar brillante, gris - verde mate y arena - rojo mate. Estructura de metal cromado brillo.

Дутое стекло представлено в белом и песочном глянцевых цветах или в матовом зеленом и красном цветах, обработанных пескоструйным способом.

**Bianco**  
White



**Ambra**  
Amber



**Rosso - Sabbia**  
Sandy - Red

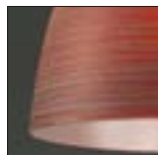

**Verde-Sabbia**  
Sandy -Green

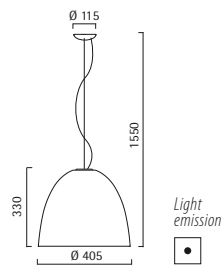

Lampada sospensione - *Pendant lamp*

- 013756** Bianco - *White*
- 013757** Ambra - *Amber*
- 013754** Verde-Sabbia - *Sandy Green*
- 013755** Rosso-Sabbia - *Sandy Red*

E27 1x105W A55

E27 1x24W TC-TSE

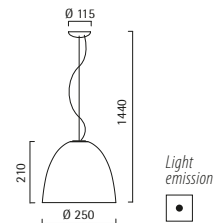

Lampada sospensione - *Pendant lamp*

- 013752** Bianco - *White*
- 013753** Ambra - *Amber*
- 013750** Verde-Sabbia - *Sandy Green*
- 013751** Rosso-Sabbia - *Sandy Red*

E27 1x70W A55

E27 1x21W TC-TSE

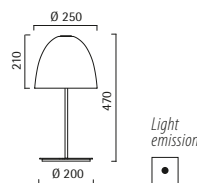

Lampada da tavolo - *Table lamp*

- 013760** Bianco - *White*
- 013761** Ambra - *Amber*
- 013758** Verde-Sabbia - *Sandy Green*
- 013759** Rosso-Sabbia - *Sandy Red*

E27 1x70W A55

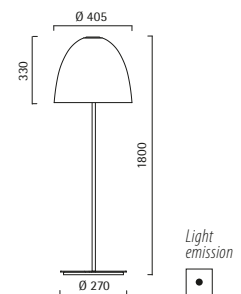

Lampada da terra - *Floor lamp*

- 013768** Bianco - *White*
- 013769** Ambra - *Amber*
- 013766** Verde-Sabbia - *Sandy Green*
- 013767** Rosso-Sabbia - *Sandy Red*

E27 1x105W A55













# BANALE

design Giandomenico Belotti, Carlo Forcolini 2001

**Diffusori in vetro soffiato opale satinato.  
Corpo tubolare in metallo cromato opaco.  
Meccanismo di inserimento e  
disinserimento di ciascuna sfera in  
termoplastico trasparente.**

Satin opal blown glass. Mat chrome metal body.  
Each sphere is inserted and extracted  
by means of clear thermoplastic gear.

Verre soufflé opale satiné.  
Corps tubulaire en métal chromé mat. Mécanisme  
de fixation et d'enlèvement de chaque glob en  
matériel thermoplastique transparent.

Satiniertem, geblasenem Opalglas. Röhrenstruktur  
aus matt verchromtem Metall. Aufsetz- und  
Abnehmmechanismus der einzelnen Kugeln aus  
transparentem thermoplastischen Material.

Difusores en vidrio soplado opal  
satinado. Cuerpo tubular en metal cromado opaco.  
Mecanismo de fijación de cada una  
de las bolas en termoplástico transparente.

Плафоны из дутого матового белого стекла.  
Ножка в матовом хроме.

**Bianco**  
White

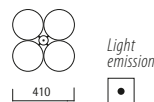
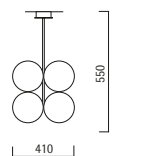

Lampada da soffitto - *Ceiling lamp*  
Vetro satinato - *Satin glass*

**013549**

E27 8x42W A55 

E27 8x14W TC-TSE 

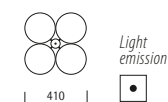
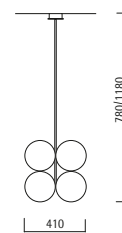

Lampada sospensione - *Pendant lamp*  
Vetro satinato - *Satin glass*

**013170**

E27 8x42W A55 

E27 8x14W TC-TSE 







# BANALE

design Giandomenico Belotti, Carlo Forcolini 2001





# BANALE

design Gandenico Belotti, Carlo Forcolini 2001





# NURA

design Lucente lab

**Serie di lampade in tessuto pongè plissettato tinta avorio. La struttura è in metallo cromato. Nura è disponibile nella versione a sospensione (singola oppure multipla), parete, tavolo e terra, entrambe dotate di varialuce.**

Range of lights in ivory pleated pongè fabric. Chrome metal structure. One-light and four-lights pendant, wall light, table and floor lamps both with dimmer.

Gamme de luminaire en tissu plissé pongé ivoire. Structure en métal chromé. Disponible en version suspension seule ou multiple, applique, lampe de table et lampe de terre qui sont disponibles avec variateur.

Leuchtenserie aus plissiertem elfenbeinfarbenem Pongé-Stoff. Die Struktur besteht aus verchromtem Metall. Nura ist als Hängeleuchte mit einem großen Diffusor oder vier kleinen Diffusoren, als Wand-, Tisch- oder Bodenleuchte erhältlich. Es können Energiesparlampen verwendet werden. Die Tisch- und Bodenversionen sind mit einem Dimmer ausgestattet.

Lámparas en tejido pongè plisado color marfil. Estructura en metal en acabado cromo. Nura es disponible en la versión suspendida a una luz o con más luces, en la versión de pared, sobremesa y de pie, las dos con atenuador.

Серия светильников с абажурами из плессированной ткани цвета слоновой кости. Корпус из хромированного металла. Светильник NURA может быть подвесным (с одним абажуром или несколькими), настенным, напольным или настольным. Последние два варианта диммируются.



**Pongè avorio**  
Ivory pongè



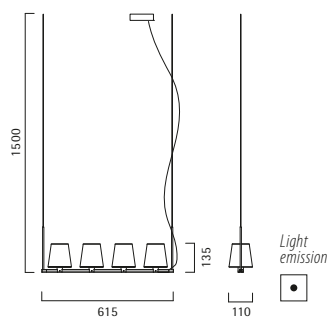

Lampada sospensione - *Pendant lamp*

**004321** Pongè avorio - *Ivory pongè*

G9 4x33W QT-13

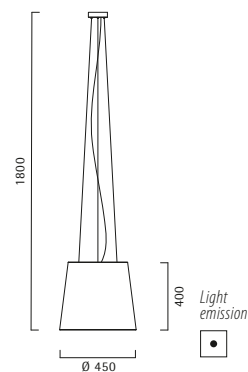

Lampada sospensione - *Pendant lamp*

**004322** Pongè avorio - *Ivory pongè*

E27 2x105W A55

E27 2x100W QT-32

E27 2x21W TC-TSE

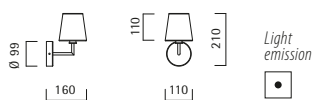

Lampada da parete - *Wall lamp*

**004320** Pongè avorio - *Ivory pongè*

G9 1x48W QT-13

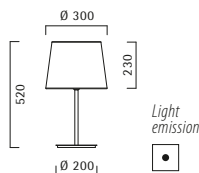

Lampada da tavolo - *Table lamp*

**004323** Pongè avorio - *Ivory pongè*

E27 1x105W A55

E27 1x100W QT-32

E27 1x21W TC-TSE

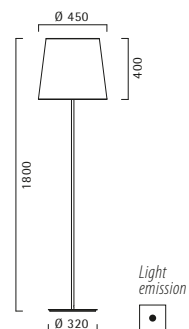

Lampada da terra - *Floor lamp*

**004324** Pongè avorio - *Ivory pongè*

E27 2x105W A55

E27 2x100W QT-32

E27 2x21W TC-TSE

NURA









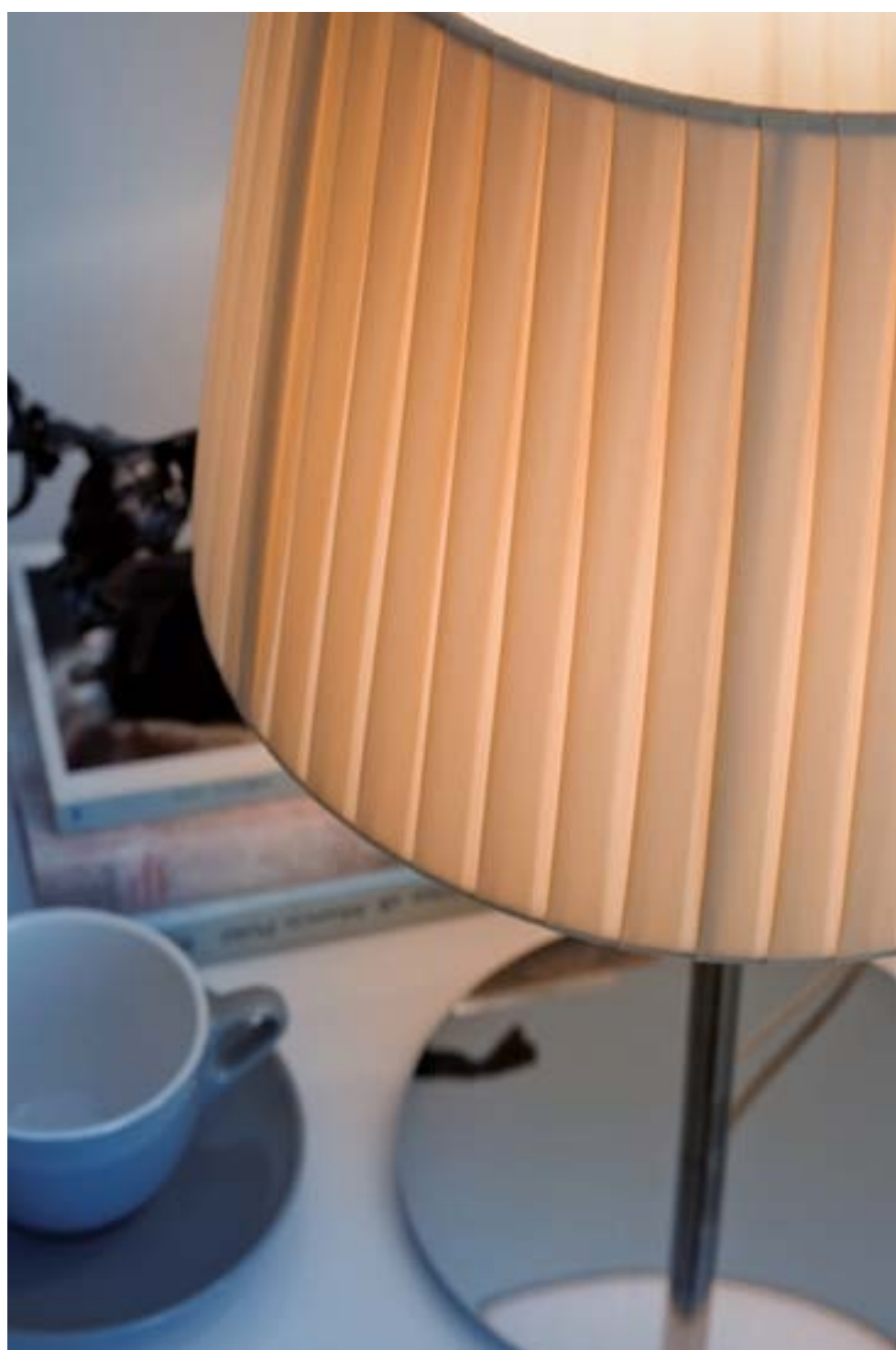

# NURA





# NOA

design Lucente Lab

**Diffusore in vetro soffiato con finitura lucida, disponibile nei colori bianco, verde e arancio. Struttura in metallo bianco opaco.**

Blown glass diffuser available in glossy white, green and orange. Matt white metal structure.

Diffuseur en verre soufflé avec finition brillante, disponible en blanc, vert ou orange. Structure en métal blanc opaque.

Diffusor in geblasenem Glas in glänzender Ausführung, in den Farben weiss, grün und orange erhältlich. Struktur in weiss mattiertem Metall.

Difusores en vidrio soplado brillante disponible en los colores blanco, verde y anaranjado. Estructura metálica barnizada blanca.

Дутое стекло представлено в белом, зеленом и оранжевом глянцевых цветах. Металлическое основание матового белого цвета.

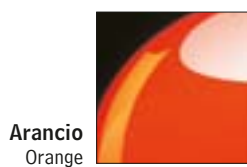
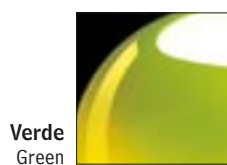
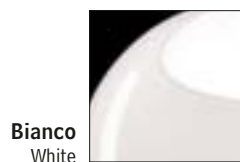

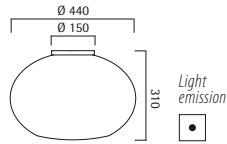

Lampada da soffitto/parete  
Ceiling/wall lamp

**009257** Bianco - White  
**009258** Arancio - Orange  
**009259** Verde - Green

E27 1x105W A55   
E27 1x24W TC-TSE

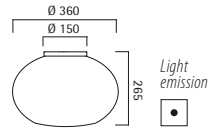

Lampada da soffitto/parete  
Ceiling/wall lamp

**009254** Bianco - White  
**009255** Arancio - Orange  
**009256** Verde - Green

E27 1x105W A55   
E27 1x21W TC-TSE

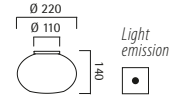

Lampada da soffitto/parete  
Ceiling/wall lamp

**009251** Bianco - White  
**009252** Arancio - Orange  
**009253** Verde - Green

G9 1x33W QT-13

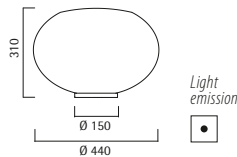

Lampada da tavolo - Table lamp

**009248** Bianco - White  
**009249** Arancio - Orange  
**009250** Verde - Green

E27 1x105W A55   
E27 1x24W TC-TSE

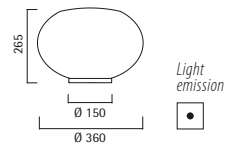
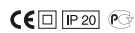

Lampada da tavolo - Table lamp

**009245** Bianco - White  
**009246** Arancio - Orange  
**009247** Verde - Green

E27 1x105W A55   
E27 1x21W TC-TSE

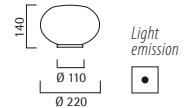
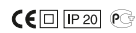

Lampada da tavolo - Table lamp

**009242** Bianco - White  
**009243** Arancio - Orange  
**009244** Verde - Green

G9 1x48W QT-13

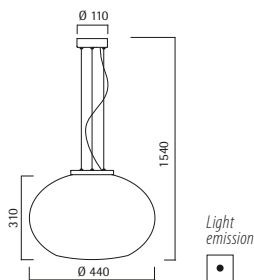

Lampada sospensione - Pendant lamp

**009239** Bianco - White  
**009240** Arancio - Orange  
**009241** Verde - Green

E27 1x105W A55   
E27 1x24W TC-TSE

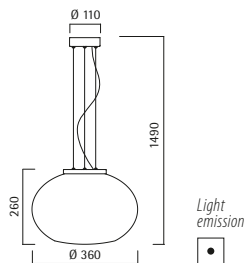

Lampada sospensione - Pendant lamp

**009236** Bianco - White  
**009237** Arancio - Orange  
**009238** Verde - Green

E27 1x105W A55   
E27 1x21W TC-TSE

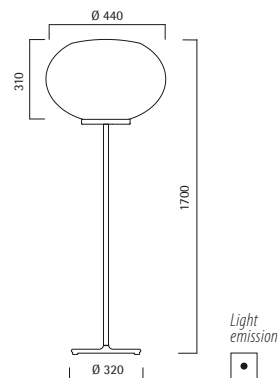

Lampada da terra - Floor lamp

**009233** Bianco - White  
**009234** Arancio - Orange  
**009235** Verde - Green

E27 1x105W A55   
E27 1x24W TC-TSE

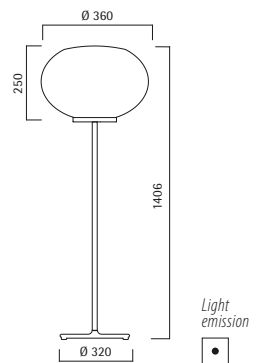
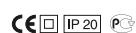

Lampada da terra - Floor lamp

**009230** Bianco - White  
**009231** Arancio - Orange  
**009232** Verde - Green

E27 1x105W A55   
E27 1x21W TC-TSE

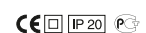



















**Struttura in metallo verniciato bianco,  
cromato o nickel spazzolato.  
Diffusore in PMMA satinato.  
Alimentazione elettronica.**

Metal structure available in white painted,  
chrome and brushed nickel.  
The PMMA acrylic diffuser is satin.  
Electronic ballast.

Structure en métal laqué blanc,  
chrome brillant et nickel brossé.  
Diffuseur en PMMA satiné.  
Ballast électronique.

Struktur aus Weiß, Verchromt,  
Nickel gebürstet Metal.  
PMMA diffuser.  
Elektronische Stromversorgung.

Estructura de metal cromado,  
níquel cepillado o blanco.  
Difusor en PMMA satinado.  
Alimentación electrónica.

Металлическое основание в никеле,  
хроме, черном и белом цветах.  
Матовый акриловый рассеиватель.  
Электронный балласт.

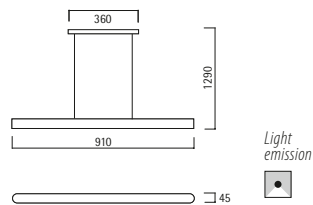

Lampada sospensione - *Pendant lamp*

- 016050** Cromo - *Chrome*
- 016051** Nickel spazzolato - *Brushed nickel*
- 016053** Bianco - *White*

G5 1x39W T5

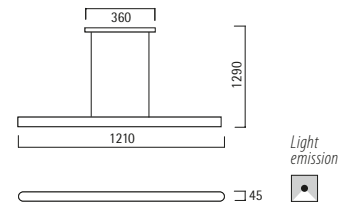

Lampada sospensione - *Pendant lamp*

- 016054** Cromo - *Chrome*
- 016055** Nickel spazzolato - *Brushed nickel*
- 016057** Bianco - *White*

G5 1x54W T5



**Bianco**  
White



**Nickel spazzolato**  
Brushed nickel



**Cromo**  
Chrome

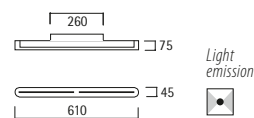

Lampada da parete - *Wall lamp*

- 016040** Cromo - *Chrome*
- 016041** Nickel spazzolato - *Brushed nickel*
- 016043** Bianco - *White*

G5 1x24W T5

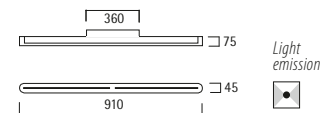

Lampada da parete - *Wall lamp*

- 016044** Cromo - *Chrome*
- 016045** Nickel spazzolato - *Brushed nickel*
- 016047** Bianco - *White*

G5 1x39W T5







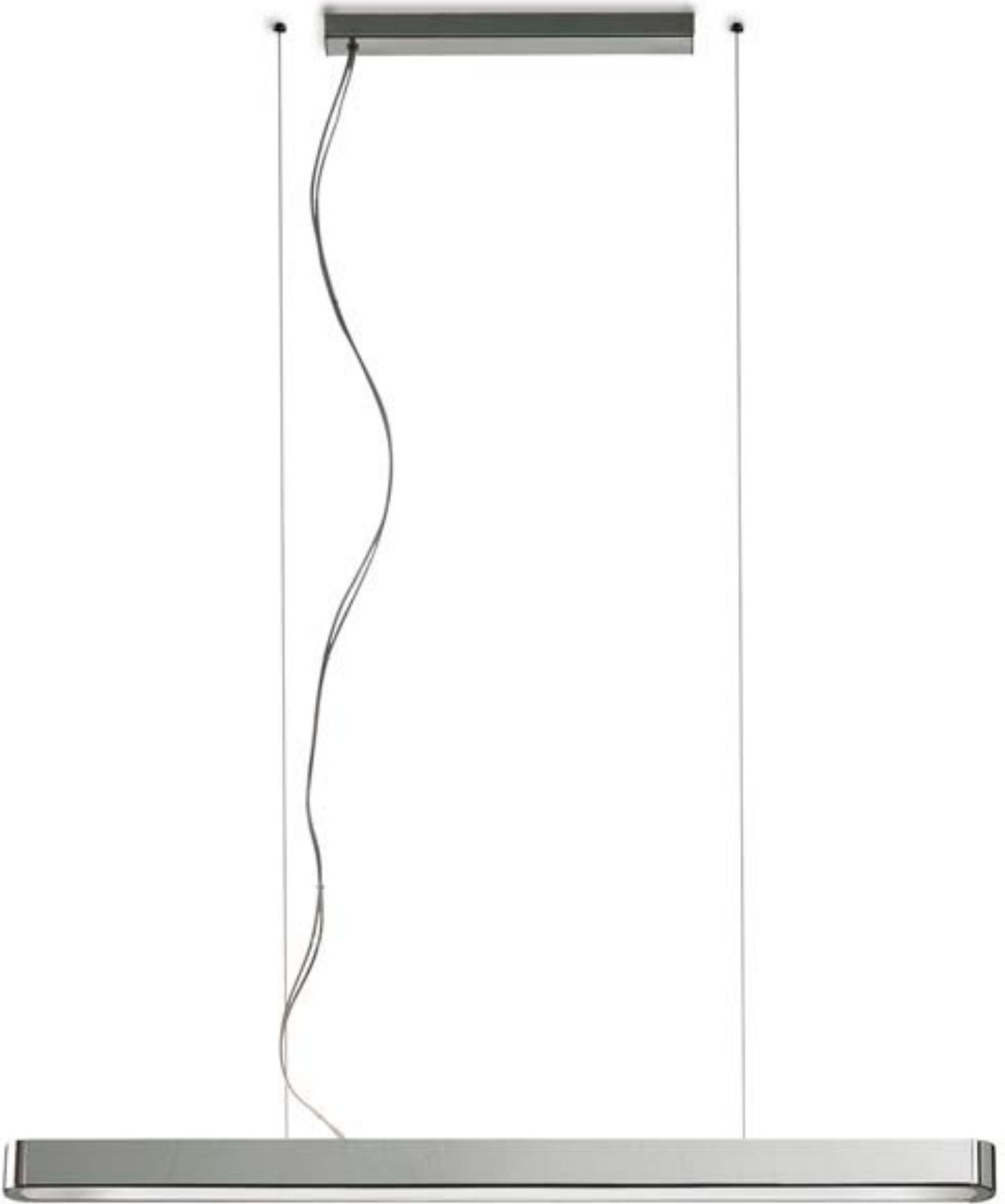



WAY





# STYLE

design Lucente Lab

**Serie di lampade in estruso di alluminio anodizzato, schermo diffusore estruso in policarbonato bianco opale 850°GW (glow wire). Finiture laterali delle sospensioni e delle lampade da parete in alluminio pressofuso cromato. Alimentazione elettronica.**

Extruded anodized aluminium lamps.  
Side chrome details on the wall and pendant lamps.  
Polycarbonate white diffuser 850° GW.  
Electronic ballast.

Séries de lampes en aluminium extrudé anodisé, écran diffuseur en polycarbonate blanc opale 850° GW (glow wire). Finitions latérales des suspensions et des appliques en fonte d'aluminium aluminium chromée.  
Alimentation électronique.

Leuchten in einem Alu-Pressprofil eloxiert, Diffusor aus opalem weißem Polycarbonat 850°GW. Seitliche Teile der Abhängung und der Wandleuchten aus verchromten Alu-Pressprofilen.  
Inklusive elektronischem Vorschaltgerät.

Serie de Lámparas con estructura en extrusión de aluminio anodizado, difusor en policarbonato blanco. Laterales de las lamparas colgadas y lampara pared en aluminio cromado vaciado por presión.  
Alimentación electrónica.

Белый рассеиватель из поликарбоната.  
Электронный балласт.



**Alluminio anodizzato**  
Anodized aluminium



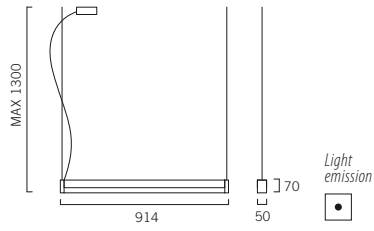

Lampada sospensione - *Pendant lamp*  
Alluminio anodizzato - *Anodized aluminium*

**013656**

G5 1x39W T5

CE

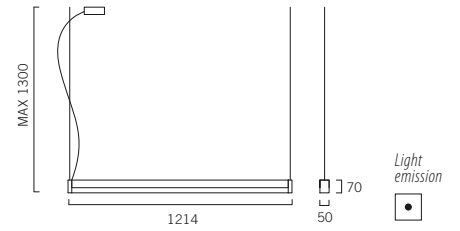

Lampada sospensione - *Pendant lamp*  
Alluminio anodizzato - *Anodized aluminium*

**013657**

G5 1x54W T5

CE

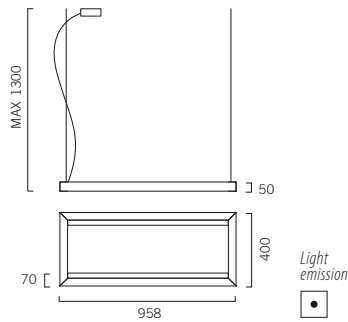

Lampada sospensione - *Pendant lamp*  
Alluminio anodizzato - *Anodized aluminium*

**013658**

G5 2x39W T5

CE

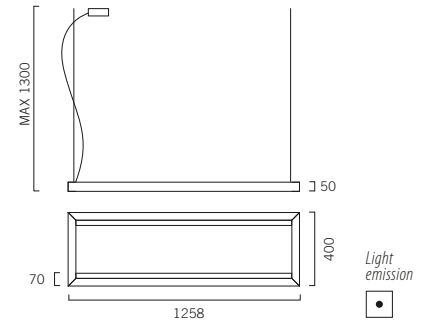

Lampada sospensione - *Pendant lamp*  
Alluminio anodizzato - *Anodized aluminium*

**013659**

G5 2x54W T5

CE

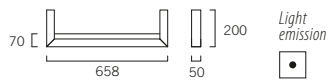

Lampada da parete/soffitto - *Wall/ceiling lamp*

**013650** Alluminio anodizzato - *Anodized aluminium*

G5 1x24W T5

CE

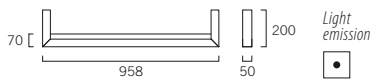

Lampada da parete/soffitto - *Wall/ceiling lamp*

**013651** Alluminio anodizzato - *Anodized aluminium*

G5 1x39W T5

CE



Lampada da parete/soffitto - *Wall/ceiling lamp*

**013652** Alluminio anodizzato - *Anodized aluminium*

G5 1x54W T5

CE

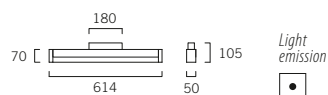

Lampada da parete/soffitto - *Wall/ceiling lamp*

**013653** Alluminio anodizzato - *Anodized aluminium*

G5 1x24W T5

CE

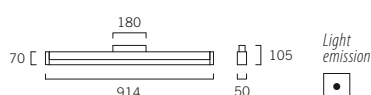

Lampada da parete/soffitto - *Wall/ceiling lamp*

**013654** Alluminio anodizzato - *Anodized aluminium*

G5 1x39W T5

CE

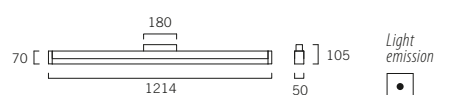

Lampada da parete/soffitto - *Wall/ceiling lamp*

**013655** Alluminio anodizzato - *Anodized aluminium*

G5 1x54W T5

CE

# STYLE







# FLY

design Roberto Favaretto

**Struttura in metallo verniciato  
con particolari di rotazione cromati.  
Riflettori in vetro bianco satinato.**

Painted metal fixture and chrome  
details. Satin white glass diffuser.

Structure en métal verni avec  
des particuliers de rotation chromés.  
Réflecteurs en verre satiné blanc.

Die Reflektors sind schwenkbar.  
Struktur aus grau lackiertem Metall.  
Die Reflektorhalterungen sind  
aus verchromtem Metall.

Estructura de metal barnizado  
con detalles de rotación cromados.  
Reflectores de vidrio blanco satinado.

Окрашенное металлическое  
основание с хромированными деталями.  
Матовое стекло.



**Bianco**  
White

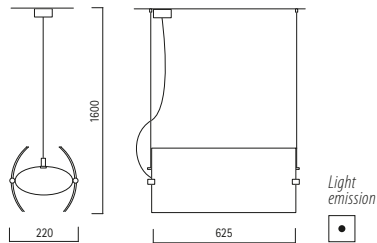

Lampada sospensione - *Pendant lamp*

**017123** Grigio - Grey

G5 2x24W T5 

alimentazione elettronica - *electronic ballast*

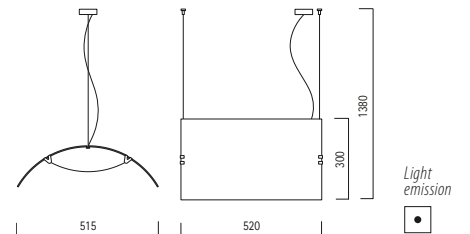

Lampada sospensione - *Pendant lamp*

**017125** Grigio - Grey

E27 2x70W A55 

E27 2x24W TC-TSE 

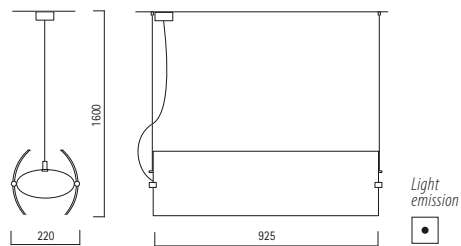

Lampada sospensione - *Pendant lamp*

**017124** Grigio - Grey

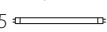
G5 2x39W T5 

alimentazione elettronica - *electronic ballast*

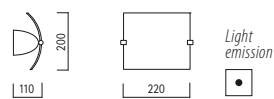

Lampada da parete - *Wall lamp*

**017120** Grigio - Grey

R7s 78mm 1x80W QT-DE 



Lampada da parete - *Wall lamp*

**017121** Grigio - Grey

G5 1x24W T5 

alimentazione elettronica - *electronic ballast*







# PROJECT 03

Modello depositato/Patented

design Thomas Sandell 2005

**Struttura in alluminio pressofuso verniciato bianco. Sospensione con tige cromata regolabile in altezza. Diffusori in vetro soffiato opalino.**

White painted die-cast aluminium structure.  
Hanging lamp with height-adjustable chrome stem. Opal blown glass diffusers.

Lampes en aluminium moulé sous pression laqué blanc. Suspension avec tige réglable en hauteur, chromée. Diffuseurs en verre soufflé opalin.

Leuchtenserie aus Aluminiumdruckguss, weiß lackiert. Hängeleuchte, höhenverstellbar verchromt. Diffusoren aus geblasenem Glas.

Estructura de aluminio vaciada a presión, barnizado en blanco. Colgante con asta cromada ajustable. Difusores de vidrio soplado opalino.

Окрашенное в белый цвет литое алюминиевое основание.  
Регулируемая по высоте ножка потолочного светильника.  
Рассеиватель из белого дутого стекла.

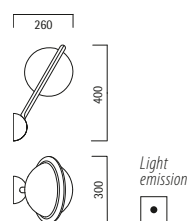

Lampada da parete - Wall lamp

**014021** Bianco - White

E27 1x70W QT-32

E27 1x24W TC-TSE

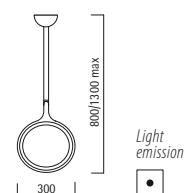

Lampada sospensione - Pendant lamp

**014020** Bianco - White

E27 1x70W QT-32

E27 1x24W TC-TSE

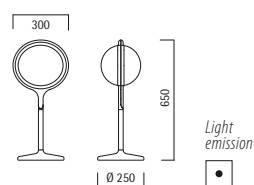

Lampada da tavolo - Table lamp

**014023** Bianco - White

E27 1x70W QT-32

E27 1x24W TC-TSE

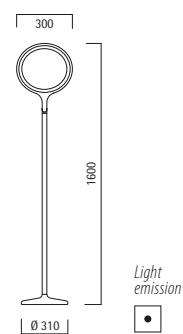

Lampada da terra - Floor lamp

**014022** Bianco - White

E27 1x70W QT-32

E27 1x24W TC-TSE



**Lampada sospensione telescopica**  
Height-adjustable pendant lamp

**Bianco**  
White







PROJECT 03  
design Thomas Sandell 2005





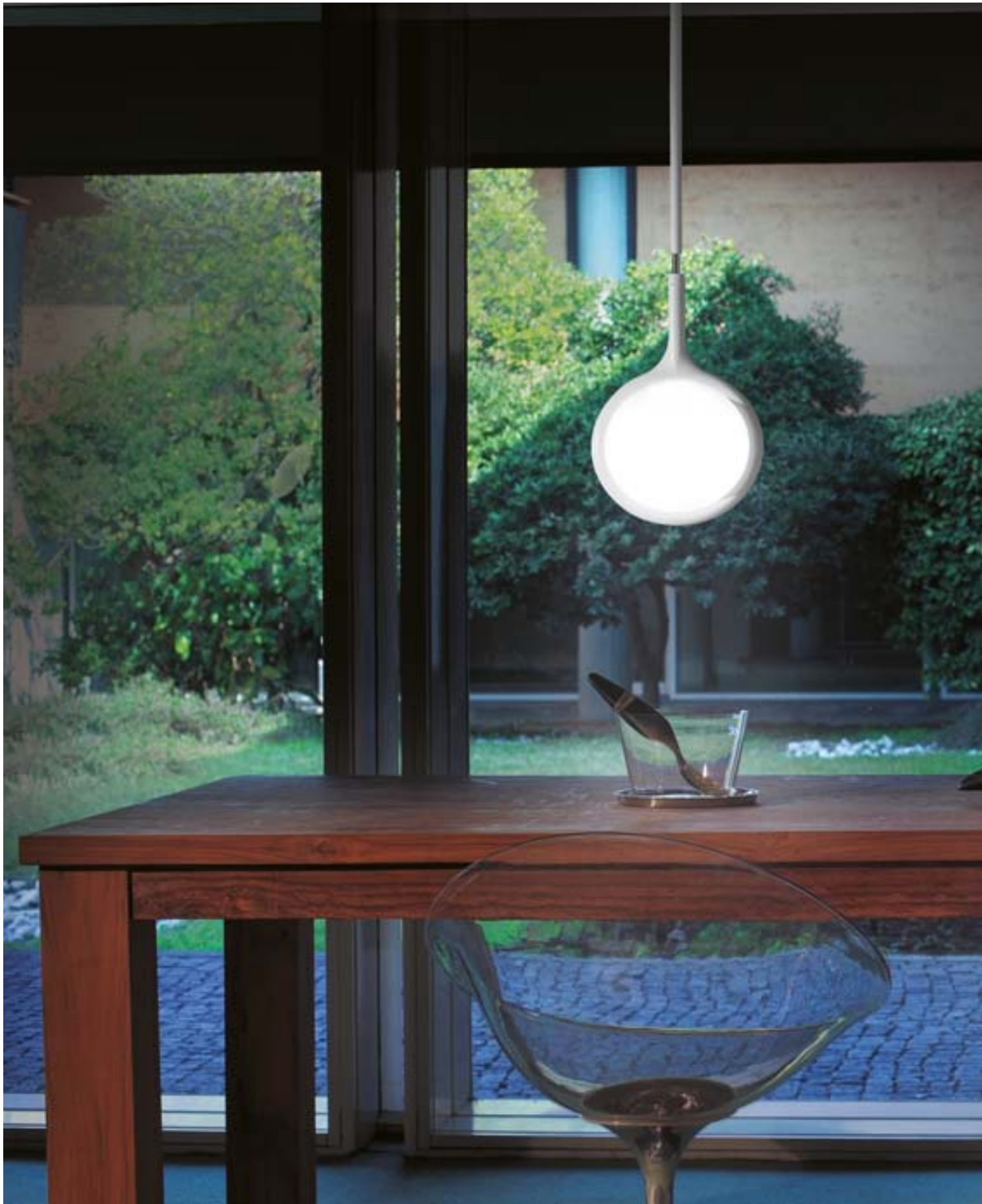

PROJECT 03  
design Thomas Sandell 2005



# REMEMBER

design Alessandro Mendini by Cleto Munari 2007

**Steli in metallo verniciato grigio,  
diffusori in tessuto bianco  
avorio, grigio, arancio.**

Grey painted metal structure.  
Fabric shades available in  
ivory-white, grey and orange.

Tiges en métal laqué gris,  
diffuseurs en tissu dans les coloris:  
blanc ivoire, gris, orange.

Graulackiertem Metallständer,  
Streukörper aus Stoff in den Farben:  
Elfenbeinweiß, Grau, Orange.

Estructura de metal pintado de gris,  
difusores de tela en varios colores:  
blanco marfil, gris, anaranjado.

Тканевый плафон представлен в цвете  
слоновой кости, сером или оранжевом цветах.  
Серое металлическое основание.

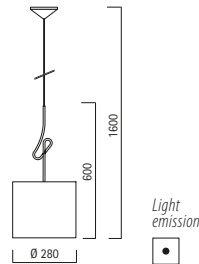

Lampada sospensione - *Pendant lamp*

**015823** Avorio - *Ivory*  
**015824** Grigio - *Grey*  
**015825** Arancio - *Orange*  
E27 1x70W A55   
CE

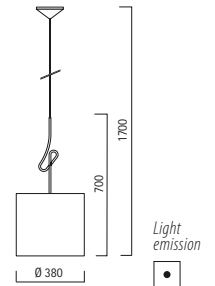

Lampada sospensione - *Pendant lamp*

**015820** Avorio - *Ivory*  
**015821** Grigio - *Grey*  
**015822** Arancio - *Orange*  
E27 1x70W A55   
CE

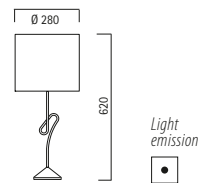

Lampada da tavolo - *Table lamp*

**015830** Avorio - *Ivory*  
**015831** Grigio - *Grey*  
**015832** Arancio - *Orange*  
E27 1x70W A55   
CE

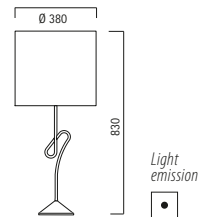

Lampada da tavolo - *Table lamp*

**015833** Avorio - *Ivory*  
**015834** Grigio - *Grey*  
**015835** Arancio - *Orange*  
E27 1x70W A55   
CE

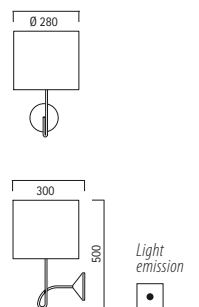

Lampada da parete - *Wall lamp*

**015826** Avorio - *Ivory*  
**015827** Grigio - *Grey*  
**015828** Arancio - *Orange*  
E27 1x70W A55   
CE

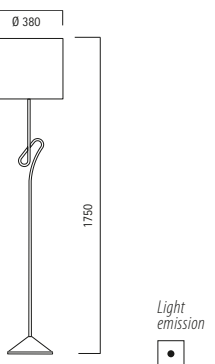

Lampada da terra - *Floor lamp*

**015836** Avorio - *Ivory*  
**015837** Grigio - *Grey*  
**015838** Arancio - *Orange*  
E27 1x70W A55   
CE





# REMEMBER

design Alessandro Mendini by Cleto Munari 2007





# REMEMBER

design Alessandro Mendini by Cleto Munari 2007





# PINKO

design Simone Deraì 2007

**Struttura in nickel spazzolato,  
diffusori in vetro stampato colorato:  
rosso, bianco, ambra trasparente  
e azzurro trasparente.**

Brushed nickel metal structure.  
Pressed glass diffusers available  
in white, red, clear amber and  
clear light blue.

Structure métallique nickel brossée.  
Diffuseur en verre dans les coloris:  
rouge, blanc, ambre transparent  
et bleu transparent.

Struktur aus Nickel gebürstet Metall.  
Lichtverteiler aus Glas in den Farben:  
Rot, Weiß, transparentem Opal,  
transparentem Bernstein.

Estructura en metal níquel cepillado.  
Difusor en vidrio en los colores:  
blanco, rojo, cobalto transparente,  
àmbra transparente.

Никелированное металлическое основание.  
Плафоны из стекла белого, красного,  
прозрачно-песочного или  
прозрачно-голубого цветов.

**Bianco**  
White



**Rosso**  
Red



**Azzurro**  
Light blue



**Ambra**  
Amber

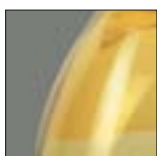

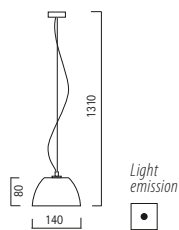

Lampada sospensione - *Pendant lamp*

- 013714** Bianco - *White*
- 013715** Rosso - *Red*
- 013716** Azzurro - *Light blue*
- 013717** Ambra - *Amber*

G9 1x48W QT-13

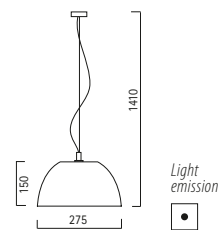

Lampada sospensione - *Pendant lamp*

- 013710** Bianco - *White*
- 013711** Rosso - *Red*
- 013712** Azzurro - *Light blue*
- 013713** Ambra - *Amber*

E27 1x52W A55

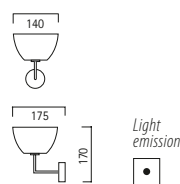

Lampada da parete - *Wall lamp*

- 013720** Bianco - *White*
- 013721** Rosso - *Red*
- 013722** Azzurro - *Light blue*
- 013723** Ambra - *Amber*

G9 1x48W QT-13

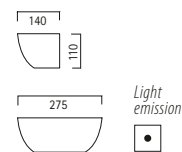

Lampada da parete - *Wall lamp*

- 013724** Bianco - *White*
- 013725** Rosso - *Red*
- 013726** Azzurro - *Light blue*
- 013727** Ambra - *Amber*

R7s 78mm 1x80W QT-DE

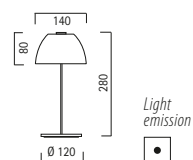

Lampada da tavolo - *Table lamp*

- 013734** Bianco - *White*
- 013735** Rosso - *Red*
- 013736** Azzurro - *Light blue*
- 013737** Ambra - *Amber*

G9 1x48W QT-13

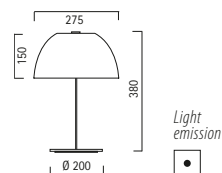
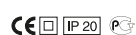

Lampada da tavolo - *Table lamp*

- 013730** Bianco - *White*
- 013731** Rosso - *Red*
- 013732** Azzurro - *Light blue*
- 013733** Ambra - *Amber*

E27 1x52W A55

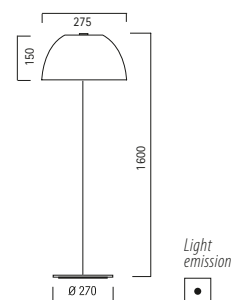
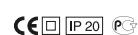

Lampada da terra - *Floor lamp*

- 013740** Bianco - *White*
- 013741** Rosso - *Red*
- 013742** Azzurro - *Light blue*
- 013743** Ambra - *Amber*

E27 1x52W A55







PINKO

design Simone D'Ercole 2007





# SPOOL

design Mårten Claesson, Eero Koivisto, Ola Rune 2005

**Riflettori in alluminio verniciato bianco o grigio argento. Filtri colorati in metacrilato: rosso porpora, verde acido e blu cobalto. Sospensione dotata di vetro diffusore satinato.**

Reflectors in white or silver grey coated aluminium. Coloured methacrylate filters in purple red, acid green and cobalt blue. The hanging lamp includes a satin-finish glass diffuser.

Réfecteurs en aluminium laqué blanc ou gris. Filtres colorés en méthacrylate rouge pourpre, vert acide et bleu cobalt. La suspension est réalisée avec un verre diffusant satiné.

Aluminiumreflektoren, weiß oder grau lackiert. Farbfilter aus Metacrylat in den Farben Purpurrot, Essiggrün und Kobaltblau. Die Hängeleuchte verfügt über einen satinierten Diffusor aus Glas.

Reflectores de aluminio barnizado blanco o gris. Filtros de metacrilato de color rojo púrpura, verde ácido y azul cobalto. El colgante está equipado con un vidrio difusor satinado.

Алюминиевые плафоны могут быть белого или темно-серого цветов. Фильтры из метакрилата представлены в красном, зеленом или синем цветах. Подвесной светильник поставляется с матовым диском из стекла. Включается легким прикосновением.

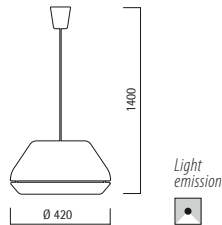

Lampada sospensione - Pendant lamp

**013807** Bianco - White  
**013808** Grigio argento - Silver grey  
E27 1x100W QT-32

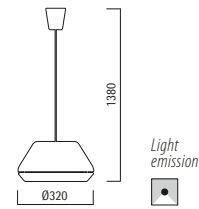

Lampada sospensione - Pendant lamp

**013806** Bianco - White  
**013804** Grigio argento - Silver grey  
E27 1x100W QT-32

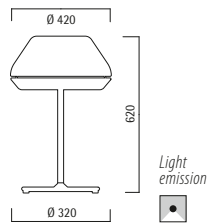

Lampada da tavolo - Table lamp

**013803** Bianco - White  
**013800** Grigio argento - Silver grey  
E27 1x100W QT-32

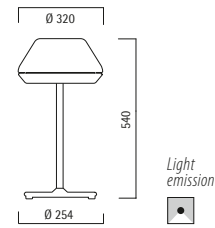
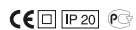

Lampada da tavolo - Table lamp

**013801** Bianco - White  
**013802** Grigio argento - Silver grey  
E27 1x100W QT-32

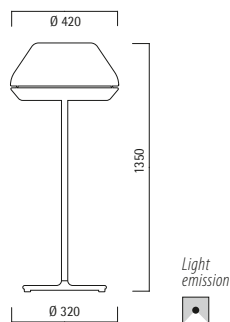

Lampada da terra - Floor lamp

**013805** Bianco - White  
**013809** Grigio argento - Silver grey  
E27 1x100W QT-32

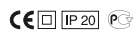

Variatore a comando sensoriale.  
Touch dimmable.

**Grigio argento**  
Silver grey



**Bianco**  
White



-  **060041** Verde - Green Ø 320
-  **060042** Verde - Green Ø 420
-  **060037** Blu - Blue Ø 320
-  **060038** Blu - Blue Ø 420
-  **060039** Rosso - Red Ø 320
-  **060040** Rosso - Red Ø 420







# SPOOL

design Mårten Claesson, Eero Koivisto, Ola Rune 2005





# SPOOL

design Mårten Claesson, Eero Koivisto, Ola Rune 2005



# RIVER

design Lucente Lab

**Serie di lampade da parete a luce indiretta a bi emissione con struttura in metallo. La parte frontale è realizzata in diverse finiture: effetto legno wenge, effetto noce nazionale, verniciato bianco opaco, verniciato effetto cor-ten e verniciato grigio. Alimentazione elettronica.**

Metal wall lights with indirect bi-emission light. The front is available in the finishes wenge-like, walnut-like, matt white painted, cor-ten-like painted and aluminium painted. Electronic ballast.

Applique en métal avec une lumière indirecte up and down. Disponible en effet wengé, effet noyé, blanc mat, gris brillant et effet cor-ten. Ballast électronique.

Wandleuchten-Serie aus Metall mit indirektem Licht und zweifacher Lichtemission. Die Front besteht aus verschiedenen Oberflächen: Wenge-Holz-Effekt, Nussholz-Effekt, mattweiße Lackierung, Cor-Ten-Stahleffekt und graue Lackierung. Elektronische Stromversorgung.

Lámpara de pared a luz indirecta biemission. Estructura en metal en los acabados: efecto wengué, efecto nogal, barnizado blanco mate, barnizado gris, barnizado efecto cor-ten. Ballast electrónico.

Серия настенных светильников, создающая эффект отраженного света с двусторонней эмиссией света. Металлический корпус снаружи может иметь следующие варианты окраски: белый матовый, серый, с эффектом кортеновской стали, под дерево венге или орех. Электронный балласт.



**Effetto legno wenge**  
Wenge like



**Effetto legno noce nazionale**  
Walnut like



**Verniciato effetto cor-ten**  
Cor-ten like



**Bianco opaco**  
Matt white



**Grigio argento**  
Silver grey

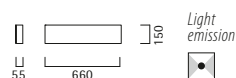

Lampada da parete - Wall lamp

- 007390** Effetto legno wenge - *Wenge like*
- 007391** Effetto legno noce nazionale - *Walnut like*
- 007392** Verniciato effetto cor-ten - *Cor-ten like painted*
- 007393** Bianco opaco - *Matt white*
- 007394** Grigio argento - *Silver grey*

G5 2x24W T5



Lampada da parete - Wall lamp

- 007385** Effetto legno wenge - *Wenge like*
- 007386** Effetto legno noce nazionale - *Walnut like*
- 007387** Verniciato effetto cor-ten - *Cor-ten like painted*
- 007388** Bianco opaco - *Matt white*
- 007389** Grigio argento - *Silver grey*

G5 2x39W T5

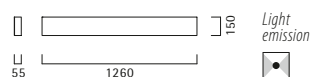

Lampada da parete - Wall lamp

- 007380** Effetto legno wenge - *Wenge like*
- 007381** Effetto legno noce nazionale - *Walnut like*
- 007382** Verniciato effetto cor-ten - *Cor-ten like painted*
- 007383** Bianco opaco - *Matt white*
- 007384** Grigio argento - *Silver grey*

G5 2x54W T5





# RIVER











# TARA

design Lucente Lab

Lampada da parete o soffitto a luce diffusa e indiretta, caratterizzata da una cornice quadrata in metallo disponibile in varie finiture: effetto legno wenge con striature argentate, foglia oro, foglia argento. Il diffusore inferiore e superiore è in PMMA opale. Alimentazione elettronica.

Diffused indirect wall or ceiling light. Metal square frame available in the finishes wenge-like with silver stripes, gold leaf and silver leaf. Front and back PMMA matt diffusers. Electronic ballast.

Applique ou plafonnier, structure en métal disponible en différentes finitions : effet wengé, feuille d'or et feuille d'argent. Diffuseur inférieur et supérieur en PMMA opale. Ballast électronique.

Wandleuchte oder Deckenleuchte mit diffusem indirektem Licht. Unterer und oberer Diffusor (vorne) bestehen aus PMMA (Polymethylacrylat) opal. Oberfläche: Wenge-Holz-Effekt mit Silberstreifen, Blattgold, Blattsilber. Elektronische Stromversorgung.

Lámpara de pared y de techo a luz indirecta, marco cuadrado en metal en los acabados: efecto wengué con estriaciones color plata, plata en hojas, oro en hojas. Difusores en PMMA mate. Ballast electrónico.

Настенный или потолочный светильник, создающий непрямой и рассеянный свет.

Металлическая рамка (корпус) может иметь следующие отделки: золотой лист, серебряный лист, цвет венге с металлизированными прожилками.

Матовые акриловые рассеиватели. Имеется встроенный электронный балласт.



**Effetto legno wenge**

Wenge like



**Foglia argento**

Silver leaf



**Foglia oro**

Gold leaf

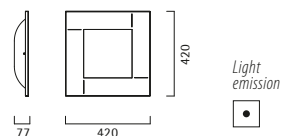

Lampada da parete/soffitto - Wall/ceiling lamp

**007320** Effetto legno wenge - *Wenge like*

**007321** Foglia argento - *Silver leaf*

**007322** Foglia oro - *Gold leaf*

2GX13 1x22W T5c

CE

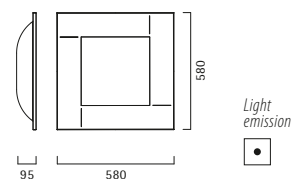

Lampada da parete/soffitto - Wall/ceiling lamp

**007323** Effetto legno wenge - *Wenge like*

**007324** Foglia argento - *Silver leaf*

**007325** Foglia oro - *Gold leaf*

2GX13 40+22W T5c

CE



TARA





Lampada da parete o soffitto con diffusore inferiore e superiore in PMMA opale. Finiture cromate. Struttura interna in metallo verniciata bianca. Alimentazione elettronica.

Wall and ceiling lamp with opal PMMA top and bottom diffusers. Chrome details. White painted inside metal frame. Electronic ballast.

Applique ou plafonnier avec diffuseur inférieur et supérieur en PMMA opale. Finitions chromées. Structure interne en métal verni blanc. Alimentation électronique.

Verchromte Wand – oder Deckenleuchte mit einem oberen und unteren Diffusor aus opalem PMMA. Innere Struktur in weiß lackiertem Metall inklusive elektronischem Vorschaltgerät.

Lampara de pared o techo con difusor inferior y superior en PMMA opalo. Acabado Cromo. Estructura interna en metal barnizado Blanco. Iluminación electronica.

Настенные и потолочные светильники с рассеивателем из поликарбоната. Электронный балласт.

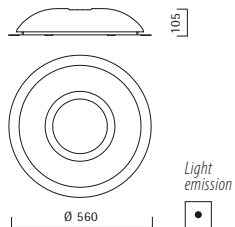

Cromo  
Chrome



Lampada da parete/soffitto - Wall/ceiling lamp

**015306** Cromo - Chrome

2GX13 40+22W T5c 

CE   IP20 

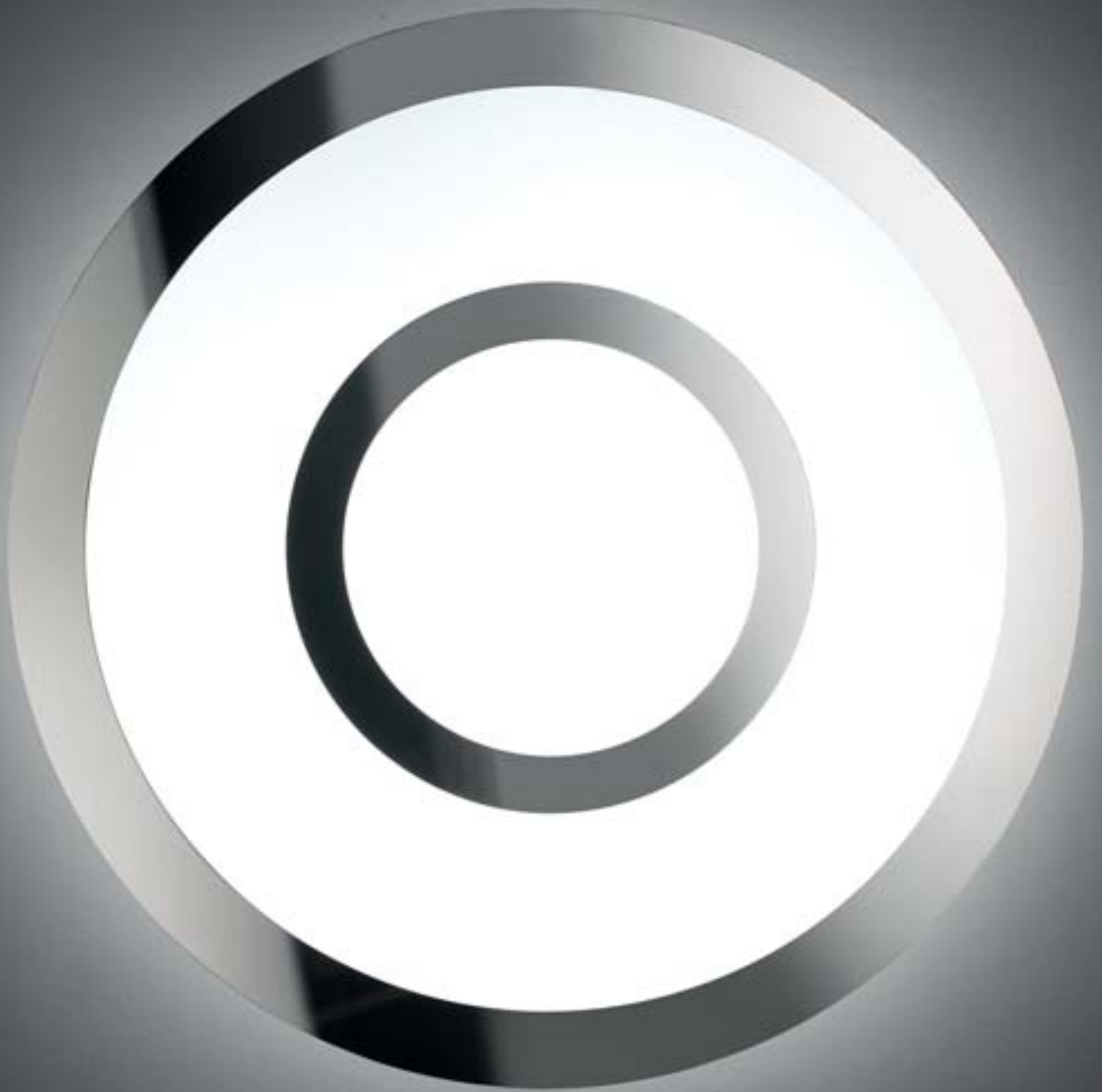



# EIGHT

design Sandro Santantonio Design 2009

**Struttura in metallo disponibile nei colori bianco opaco, verniciato rame oppure cromo lucido. Diffusore inferiore e superiore in PMMA opale. Nella versione Ø 200 diffusore inferiore e superiore in vetro.**

Metal structure available in mat white, copper painted and glossy chrome. Opal PMMA diffusers. Glass diffusers only for the Ø 200.

Structure en métal disponible en blanc opaque, cuivre verni ou chrome lustré. Diffuseur inférieur et supérieur en PMMA opale. Dans la version Ø 200 diffuseur inférieur et supérieur en verre.

Metalstruktur erhältlich in den Farben weiss matt, kupfer lackiert oder in chrom glänzend. Der Diffusor in PMMA opal. Den Glas-Diffusor gibt es nur in der Version Ø 200.

Estructura metálica barnizada blanca mate, cobre o en cromo brillo. Difusores inferior y superior de PMMA opalino. Por el modelo Ø 200 difusores de vidrio.

Металлическое основание может быть в матовом белом, крашенном медном или хромированном цветах. Рассеиватель из метакрилата. Так же возможен вариант рассеивателя из стекла для светильника f 200.

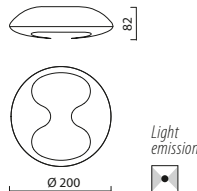

Lampada da parete/soffitto - Wall/ceiling lamp

**008862** Bianco - White  
**008860** Cromo - Chrome  
**008861** Rame - Copper

G9 2x20W QT-13



**008865** Bianco - White  
**008863** Cromo - Chrome  
**008864** Rame - Copper

GX53 1x9W

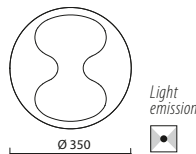
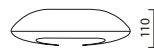

Lampada da parete/soffitto - Wall/ceiling lamp

**008878** Bianco - White  
**008876** Cromo - Chrome  
**008877** Rame - Copper

E27 2x21W TC-TSE

**008872** Bianco - White  
**008870** Cromo - Chrome  
**008871** Rame - Copper

G24q-2 2x18W TC-DE

Alimentazione elettronica - Electronic ballast

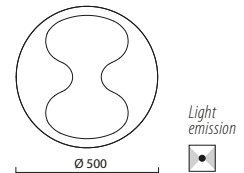
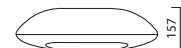

Lampada da parete/soffitto - Wall/ceiling lamp

**008891** Bianco - White  
**008889** Cromo - Chrome  
**008890** Rame - Copper

E27 2x24W TC-TSE

**008888** Bianco - White  
**008886** Cromo - Chrome  
**008887** Rame - Copper

G24q-3 2x26W TC-DE

Alimentazione elettronica - Electronic ballast

**008882** Bianco - White  
**008880** Cromo - Chrome  
**008881** Rame - Copper

2GX13 40+22W T5c

Alimentazione elettronica - Electronic ballast

**008885** Bianco - White  
**008883** Cromo - Chrome  
**008884** Rame - Copper

GR10q 1x38W TC-DDE

Alimentazione elettronica - Electronic ballast





# EIGHT

design Sandro Santantonio Design 2009





# EIGHT 1000

design Sandro Santantonio Design 2009

**Lampada con struttura metallica e rivestimento in tessuto elasticizzato sfoderabile e lavabile. Tessuto disponibile nei colori avorio oppure arancio.**

Metal structure and removable and washable stretch-fabric available in ivory and orange.

Lampe avec structure métallique et revêtement en tissu élastique amovible et lavable. Tissu disponible en ivoire ou orange.

Leuchte mit Metalstruktur in weiss matt lackiert und mit einem waschbaren und elastischem Gewebe ummantelt. Das Gewebe ist in den Farben elfenbein oder orange erhältlich.

Estructura metálica barnizada revestida de tejido elástico, desfundable y lavable. Tejido disponible en los colores marfil y anaranjado.

Металлическое основание, ткань белого или оранжевого цветов, которую можно снять и постирать по необходимости.



**Avorio**  
Ivory



**Arancio**  
Orange

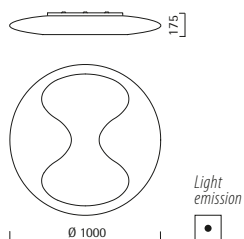

Lampada da parete/soffitto - Wall/ceiling lamp

**008900** Avorio - Ivory

**008901** Arancio - Orange

E27 5x21W TC-TSE 



# GRIFO IP44

design Lucente Lab

**Struttura in metallo verniciato alluminio.**  
**Diffusore in vetro soffiato opale satinato.**  
**Fissaggio del vetro a baionetta.**  
**Grado di protezione IP44.**  
**Alimentazione elettronica.**

Aluminium painted metal structure.  
Opal satin blown glass. Twist-and-lock fixing.  
IP44 rated. Electronic ballast.

Structure en métal verni gris. Verre soufflé  
satiné opale. Fixation du verre à baïonnette.  
IP44. Ballast électronique.

Struktur aus Metall mit grauer Lackierung.  
Lichtverteiler aus geblasenem, satiniertem  
Opalglas. Bajonetteverschluss. IP44.  
Elektronische Stromversorgung.

Estructura en metal lacado gris y vidrio  
soplado opal satinado. Fisaje del vidrio a  
bayoneta. IP44. Ballast electrónico.

Алюминиевое основание.  
Белое матовое дутое стекло.  
Легкое крепление. IP44.  
Электронный балласт.



**La serie è disponibile nella versione  
in emergenza da 1H o da 3H.**  
**The range is available with emergency  
working 1H or 3H.**

**Grigio**  
Grey

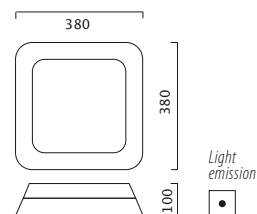

Lampada da parete/soffitto - Wall/ceiling lamp  
Grigio - Grey

E27 2x42W A55  **007570**

G24q-3 2x26W TC-DE  **007571**

GR10q 1x38W TC-DDE  **007572**







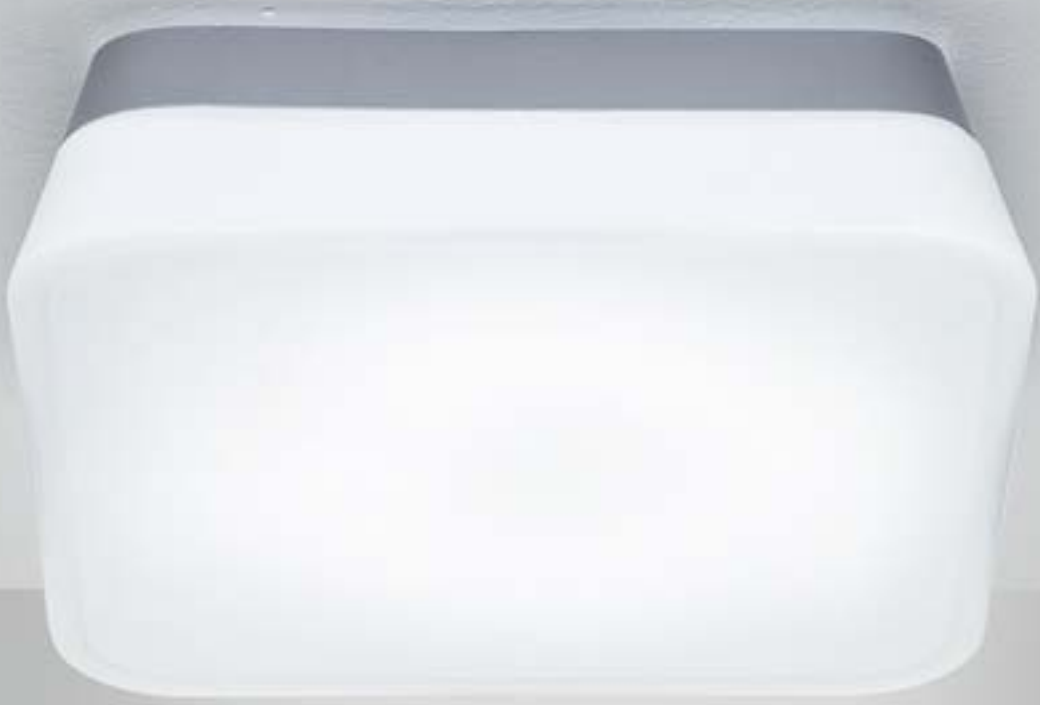

# MAX H

design Roberto Favaretto

**Struttura in estruso di alluminio anodizzato e metallo microforato cromato. Giunti in policarbonato trasparente. Vetro di protezione in pirex satinato.**

Structure in extruded anodized aluminium and chromed micro-perforated metal. Clear polycarbonate joints. Satin pyrex seat protection glass.

Structure en extrudé d'aluminium anodisé satiné. Joints en polycarbonate transparent. Diffuseur supérieur en tôle micro perforée chromée. Verre de protection en pyrex satiné.

Struktur aus eloxiertem, satiniertem Alumiuniupressprofil. Verbindungen aus transparentem Polycarbonat. Oberer Lichtverteiler aus perforiertem, verchromtem Blech. Schutzglas aus satiniertem Pirex.

Estructura en extruso de aluminio anodizado satinado. Juntas en policarbonado transparente. Difusor superior en chapa microperforada cromada. Vidrio de protección en pirex satinado.

Корпус выполнен из штампованного анодированного алюминия. Перфорированные декоративные вставки. В стыковые крепления из прозрачного поликарбоната. Рассеиватели из жаростойкого стекла.

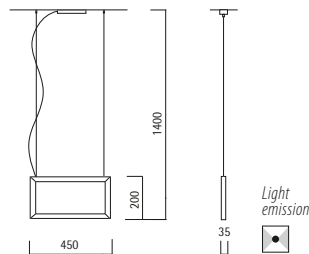

Lampada sospensione - *Pendant lamp*  
Alluminio anodizzato - *Anodized aluminium*

**013620**

R7s 78mm 1x120W QT-DE Sopra - Up

R7s 78mm 1x80W QT-DE Sotto - Down

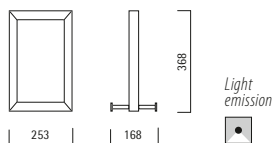

Lampada da tavolo - *Table lamp*  
Alluminio anodizzato - *Anodized aluminium*

**013605**

G9 1x60W QT-14

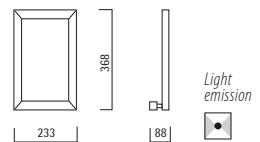

Lampada da parete - *Wall lamp*  
Alluminio anodizzato - *Anodized aluminium*

**013603**

R7s 78mm 1x80W QT-DE

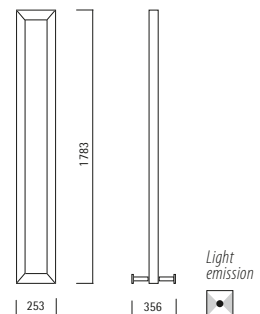

Lampada da terra - *Floor lamp*  
Alluminio anodizzato - *Anodized aluminium*

**013604**

R7s 78mm 1x120W QT-DE

**Alluminio anodizzato**  
Anodized aluminium





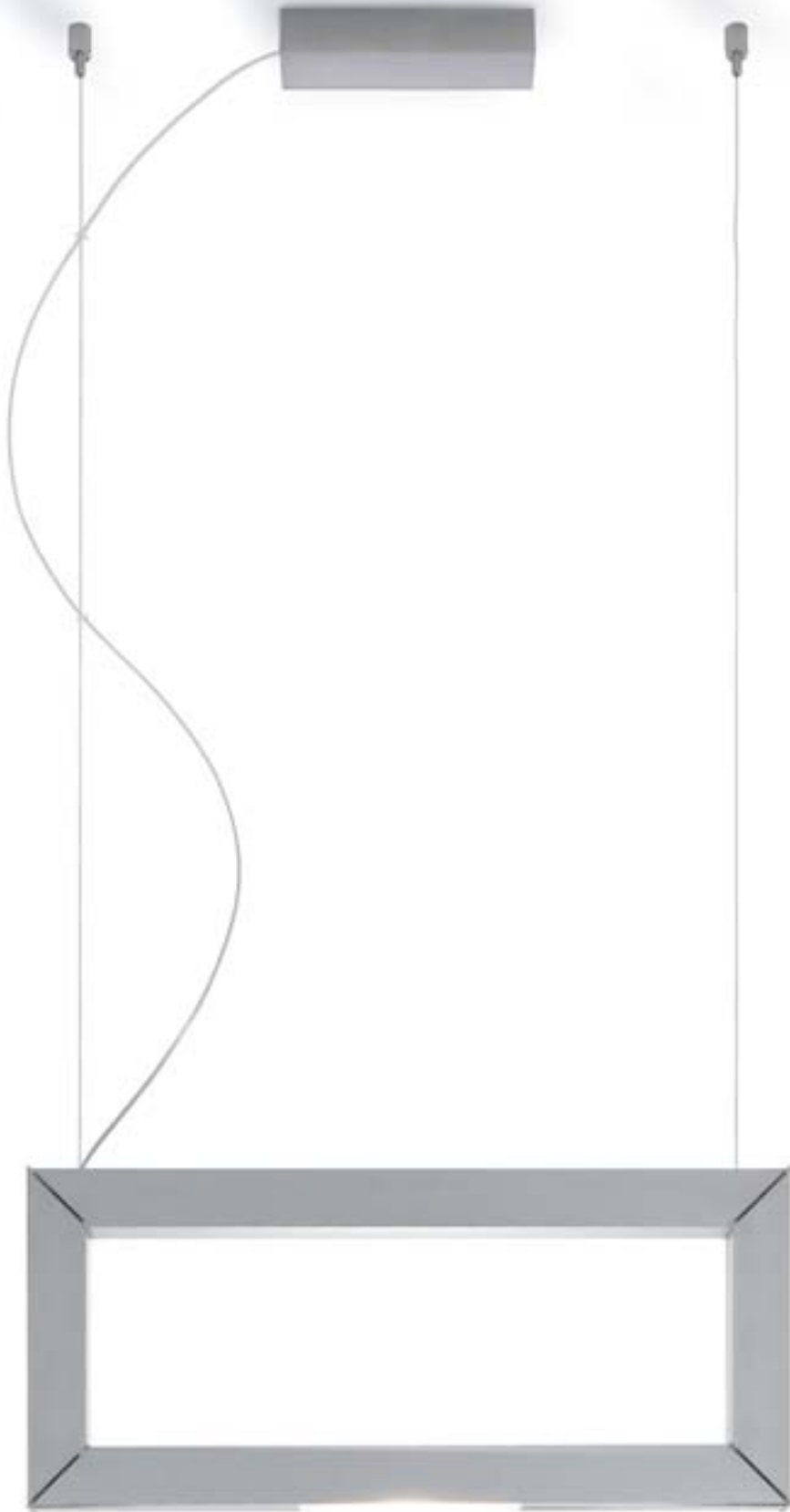



MAX H







**Serie da parete e sospensione.**  
**Struttura in estruso di alluminio**  
**anodizzato e metallo microforato cromato.**  
**Vetro di protezione in pirex satinato.**

Wall lamps and pendants.  
 Structure in extruded anodized aluminium  
 and chrome microperforated metal.  
 Satin pyrex seat protection glass.

Applique et suspension.  
 Structure en extrudé d'aluminium anodisé  
 et métal microperforé chromé.  
 Verre de protection en pyrex satiné.

Wandleuchte und Hängeleuchte  
 Struktur aus eloxiertem  
 stranggepresstem Aluminium und  
 verchromtem Siebblech. Schutzglas  
 aus satiniertem Pyrex.

Lámpara de pared y suspensión.  
 Estructura en extruido de aluminio anodizado  
 y metal microperforado cromado.  
 Vidrio de protección en pirex satinado.

Корпус выполнен из штампованного  
 анодированного алюминия.  
 Перфорированные декоративные вставки.  
 Рассеиватели из жаростойкого стекла.

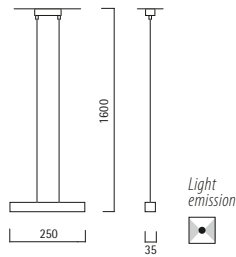

Lampada sospensione - *Pendant lamp*  
 Alluminio anodizzato - *Anodized aluminium*

**000101**  
 R7s 78mm 1x120W QT-DE

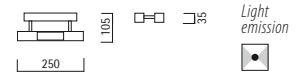

Lampada da parete - *Wall lamp*  
 Alluminio anodizzato - *Anodized aluminium*

**000102**  
 R7s 78mm 1x120W QT-DE

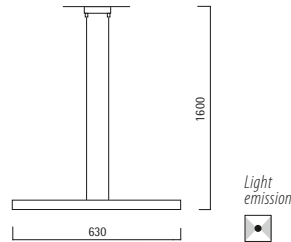

Lampada sospensione - *Pendant lamp*  
 Alluminio anodizzato - *Anodized aluminium*

**000100**  
 R7s 78mm 2x120W QT-DE

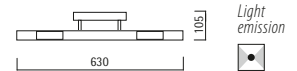

Lampada da parete - *Wall lamp*  
 Alluminio anodizzato - *Anodized aluminium*

**000103**  
 R7s 78mm 2x120W QT-DE

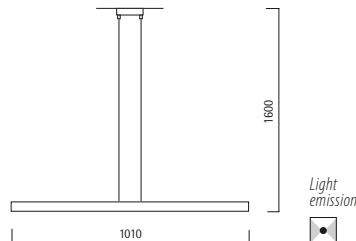

Lampada sospensione - *Pendant lamp*  
 Alluminio anodizzato - *Anodized aluminium*

**000106**  
 R7s 78mm 3x120W QT-DE

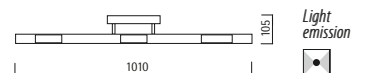

Lampada da parete - *Wall lamp*  
 Alluminio anodizzato - *Anodized aluminium*

**000105**  
 R7s 78mm 3x120W QT-DE

**Alluminio anodizzato**  
 Anodized Aluminium





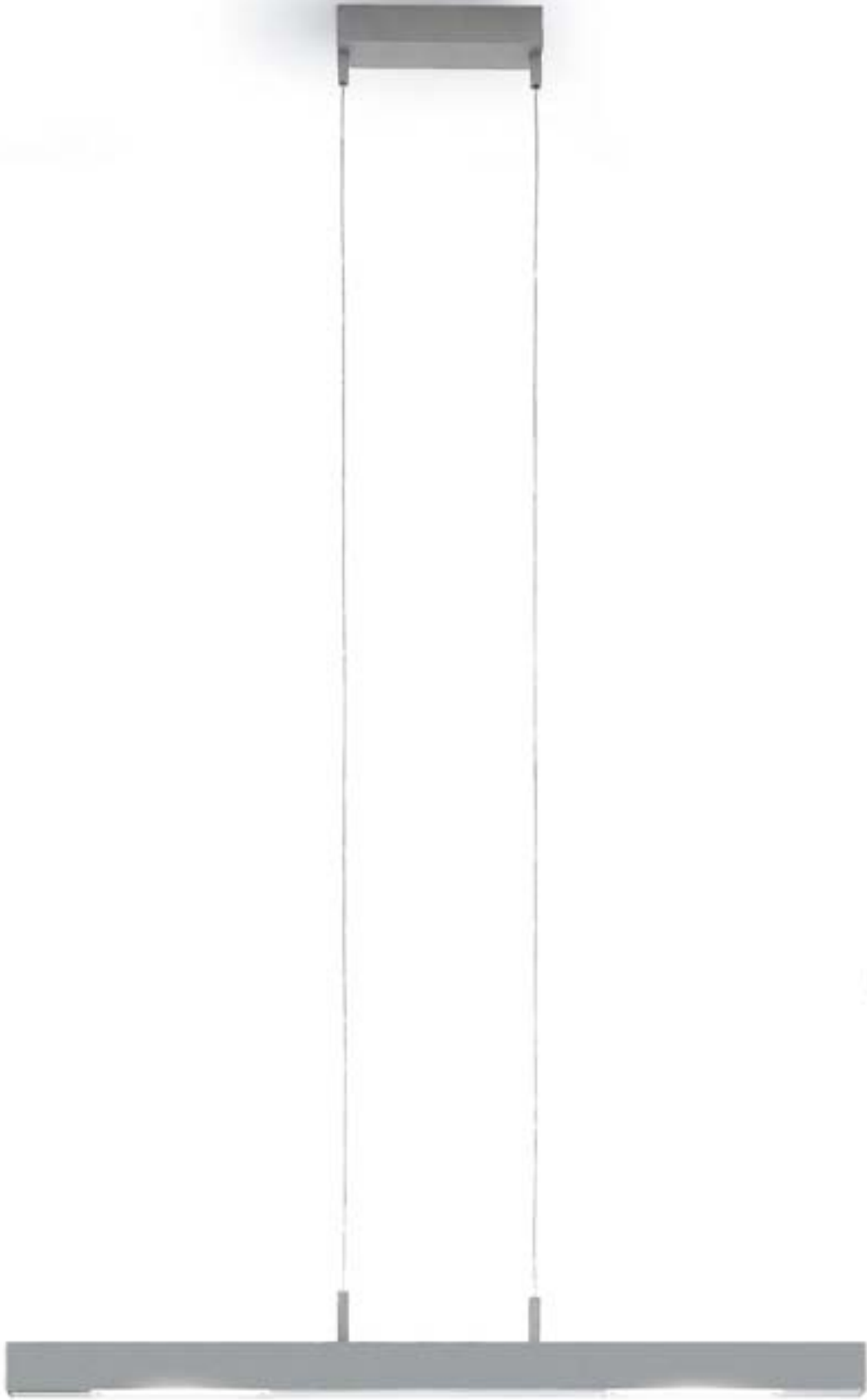

MAX





MAX

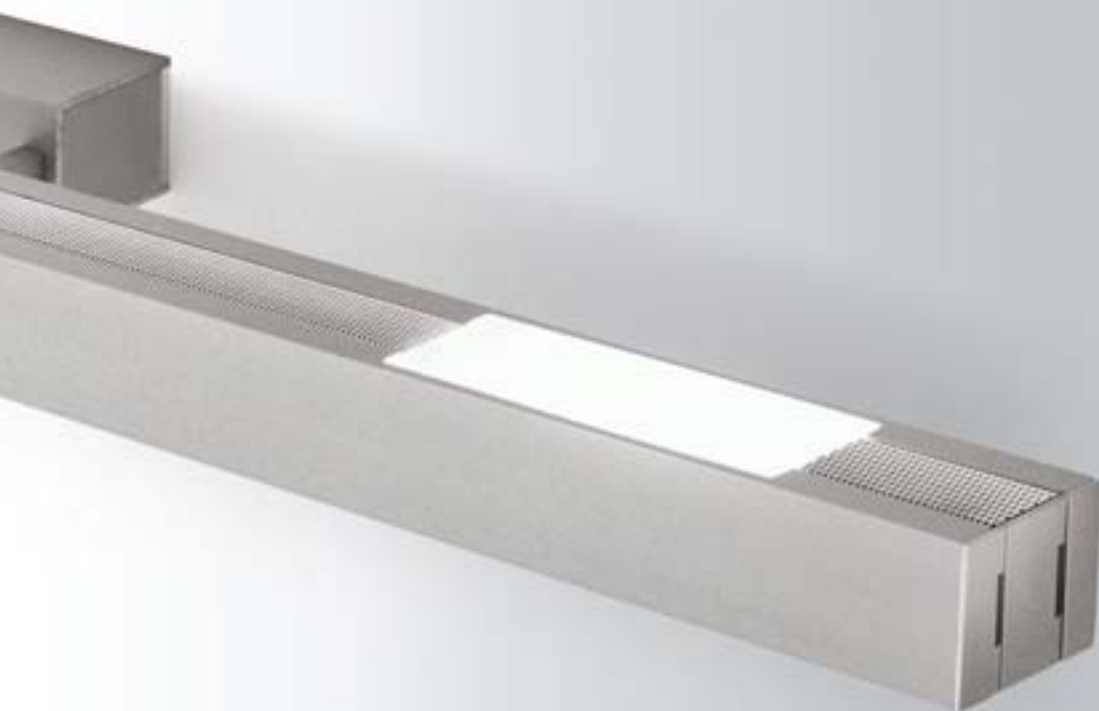

# MAX

design Roberto Favaretto

**Serie di lampade da tavolo, lettura e terra orientabili. Struttura in alluminio estruso, base in metallo verniciato. Elementi di areazione e steli cromati.**

Adjustable table, reading and floor lamps. Extruded aluminium body and painted metal base. Chrome stems and ventilation details.

Lampes de table, de lecture et de sol orientable. Structure en aluminium extrudé, base en métal laqué. Éléments d'aération et pieds chromés.

Tischleuchten, Bodenleuchten und Leseleuchten mit direktem und indirektem Licht mit doppelter Emission. Aluminium fließgepresst. Basis aus lackiertem Metall. Belüftungselemente und verchromte Schäfte.

Lámparas de mesa, de lectura y de pie orientable. Estructura de aluminio extruido, base de metal barnizado. Elementos de ventilación y astas cromados.

Корпус выполнен из штампованного алюминия. Окрашенное металлическое основание. Хромированная ножка.

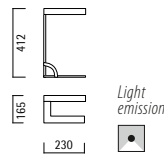

Lampada da tavolo - *Table lamp*  
Alluminio - *Aluminium*

**000114**

G9 1x60W QT-14

CE

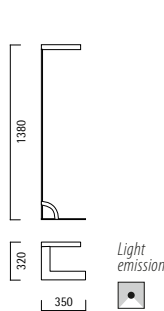

Lampada da lettura - *Reading lamp*  
Alluminio - *Aluminium*

**000112**

G9 1x60W QT-14

CE

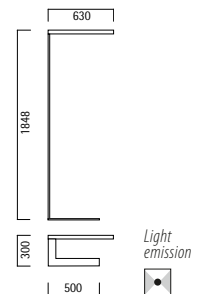

Lampada da terra - *Floor lamp*  
Alluminio - *Aluminium*

**000113**

R7s 78mm 2x120W QT-DE

CE

**Alluminio**  
Aluminium









MAX



# INTERNOS

design Roberto Favaretto

**Doppio diffusore  
in vetro satinato e curvato.  
Struttura metallica cromata  
o nickel spazzolato.**

Double diffuser in satin glass.  
Chrome and brushed nickel  
metal structure.

Double diffuseur en verre satiné  
et courbé fixé sur une structure  
métallique chromée ou nickel brossée.

In eine verchromte oder vernickelte und gebürstete  
Metallstruktur eingesetzter doppelter Lichtverteiler  
aus bandförmig geschwungenem, satiniertem Glas.

Doble difusor en vidrio satinado curvado.  
Estructura metálica en níquel  
cepillado o cromada.

Рассеиватели из матового стекла.  
Основание в хроме или никеле.

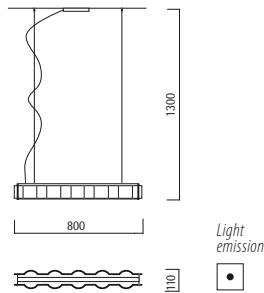

Lampada sospensione - *Pendant lamp*

**009086** Cromo - *Chrome*

**009092** Nickel spazzolato - *Brushed nickel*

G9 5x33W QT-13

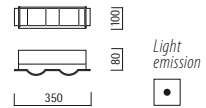

Lampada da parete - *Wall lamp*

**013575** Cromo - *Chrome*

**013577** Nickel spazzolato - *Brushed nickel*

G9 2x33W QT-13

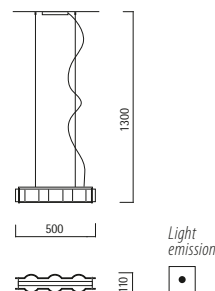

Lampada sospensione - *Pendant lamp*

**009085** Cromo - *Chrome*

**009089** Nickel spazzolato - *Brushed nickel*

G9 3x33W QT-13

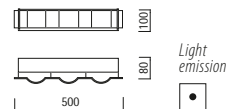

Lampada da parete - *Wall lamp*

**013570** Cromo - *Chrome*

**013572** Nickel spazzolato - *Brushed nickel*

G9 3x33W QT-13

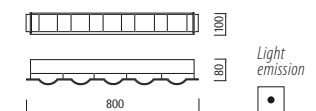

Lampada da parete - *Wall lamp*

**013571** Cromo - *Chrome*

**013573** Nickel spazzolato - *Brushed nickel*

G9 5x33W QT-13



**Cromo**  
Chrome



**Nickel spazzolato**  
Brushed nickel

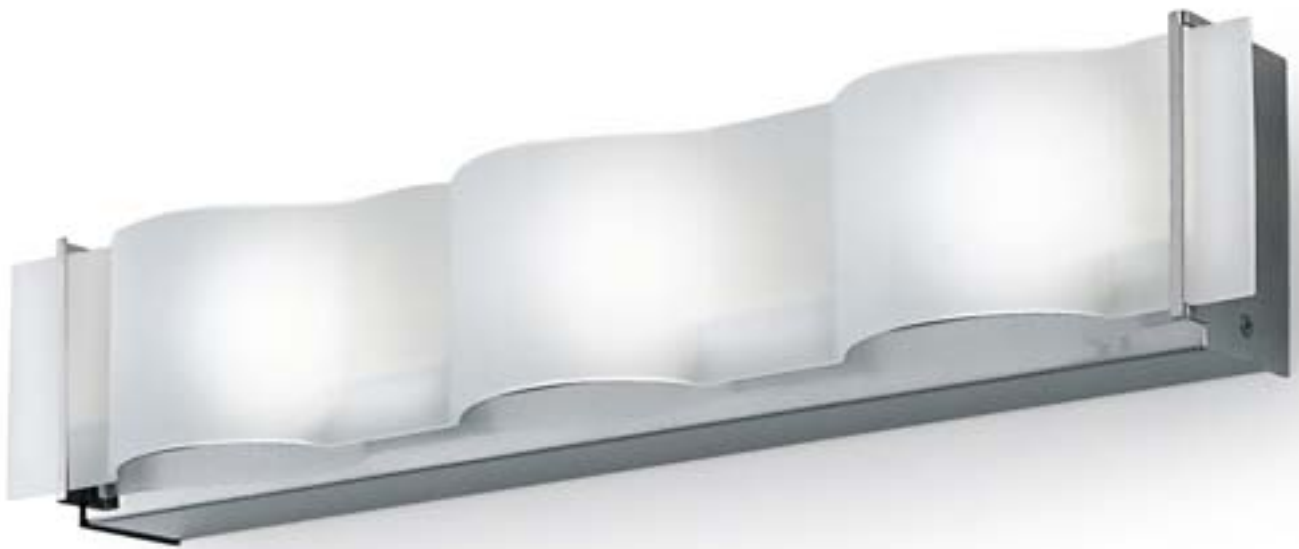

# INTERNOS





# TAMBURO

design Roberto Favaretto

**Struttura circolare in metallo cromato (verniciato nella versione diam. 500) con filtri colorati a scelta arancio, blu o trasparente. Diffusore in metacrilato opalino lucido. Alimentazione elettronica.**

Metal round structure, chromed for the 370 diameter lamp series and grey painted for the 500 diameter. Orange, blue and transparent filters to complete the lamp. Glossy opal acrylic diffuser. Electronic ballast.

Corps circulaire en métal chromé (laqué dans la version de diamètre 500), avec des filtres colorés orange, bleu ou transparent au choix. Diffuseur en méthacrylate opalin brillant. Ballast électronique.

Struktur des runden Lampenkörpers aus verchromten Metall (in der Ausführung mit einem Durchmesser von 500 lackiert) mit Farbfiltern in Orange, Blau bzw. transparent zur Ergänzung. Streukörper aus opalem, glänzendem Methacrylat. Elektronische Stromversorgung.

Estructura circular de metal cromado (pintado en la versión con diám. 500) completa con filtros de color anaranjado, azul o transparente. Difusor de metacrilato opalino brillo. Ballast electrónico.

Металлическое основание. Светильники диаметром 370мм выполнены в хроме. Корпус светильников диаметром 500мм окрашен в серый цвет. Фильтры на выбор оранжевого, синего или прозрачного цветов. Акриловый рассеиватель белого цвета. Регулируемая по высоте ножка потолочного светильника. Включается легким прикосновением. Электронный балласт.



**Cromo**  
Chrome



**Grigio argento**  
Silver grey



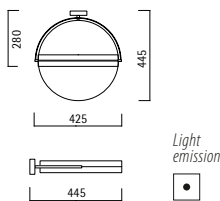

Lampada da soffitto/parete - *Ceiling/wall lamp*

**012601** Metallo cromato e verniciato  
*Chromed and painted metal*

2GX13 1x55W T5c

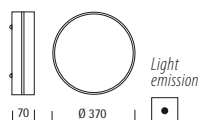

Lampada da soffitto/parete - *Ceiling/wall lamp*

**012603** Cromo - *Chrome*

2GX13 1x55W T5c

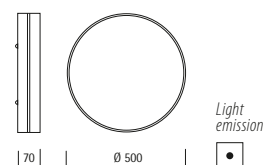

Lampada da soffitto/parete - *Ceiling/wall lamp*

**012604** Grigio argento - *Silver grey*

2GX13 40+22W T5c

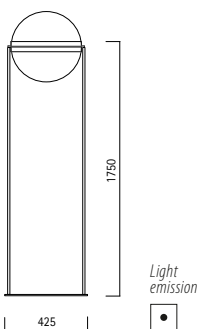

Lampada da terra - *Floor lamp*

**012607** Metallo cromato e verniciato  
*Chromed and painted metal*

2GX13 1x55W T5c

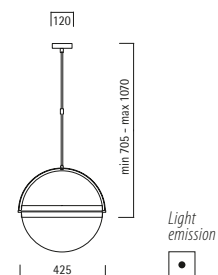

Lampada sospensione - *Pendant lamp*

**012605** Metallo cromato e verniciato  
*Chromed and painted metal*

2GX13 1x55W T5c



Filtro a completamento lampada.  
*Filter to be selected from the following options.*



**060045** Trasparente - Clear Ø 370  
**060044** Trasparente - Clear Ø 500

**060046** Blu - Blue Ø 370  
**060048** Blu - Blue Ø 500

**060047** Rosso - Red Ø 370  
**060043** Rosso - Red Ø 500

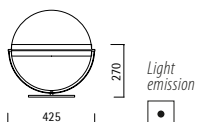

Lampada da tavolo - *Table lamp*

**012611** Metallo cromato e verniciato  
*Chromed and painted metal*

2GX13 1x55W T5c

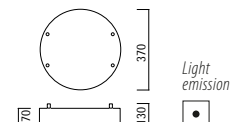

Lampada da tavolo - *Table lamp*

**012609** Metallo cromato  
*Chromed metal*

2GX13 1x55W T5c









# TAMBURO



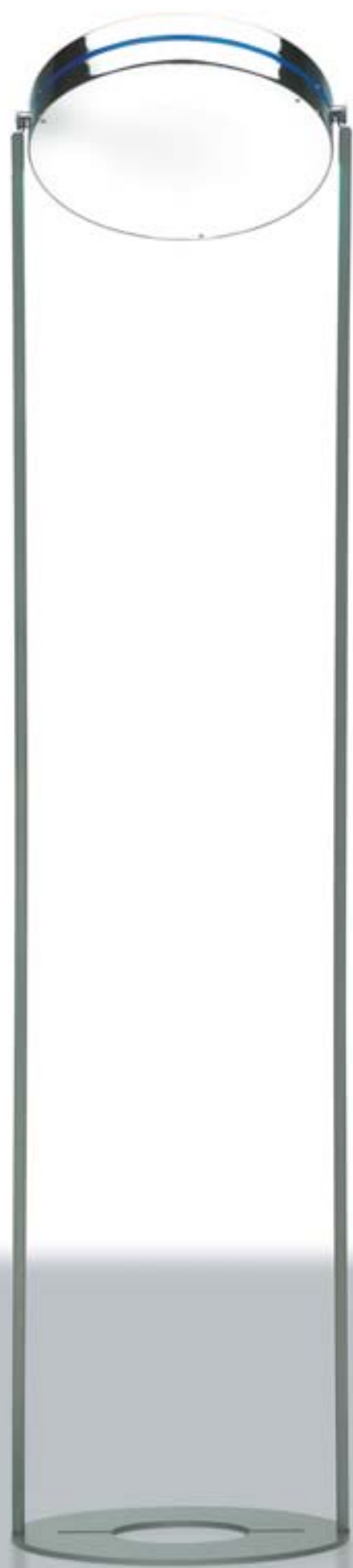
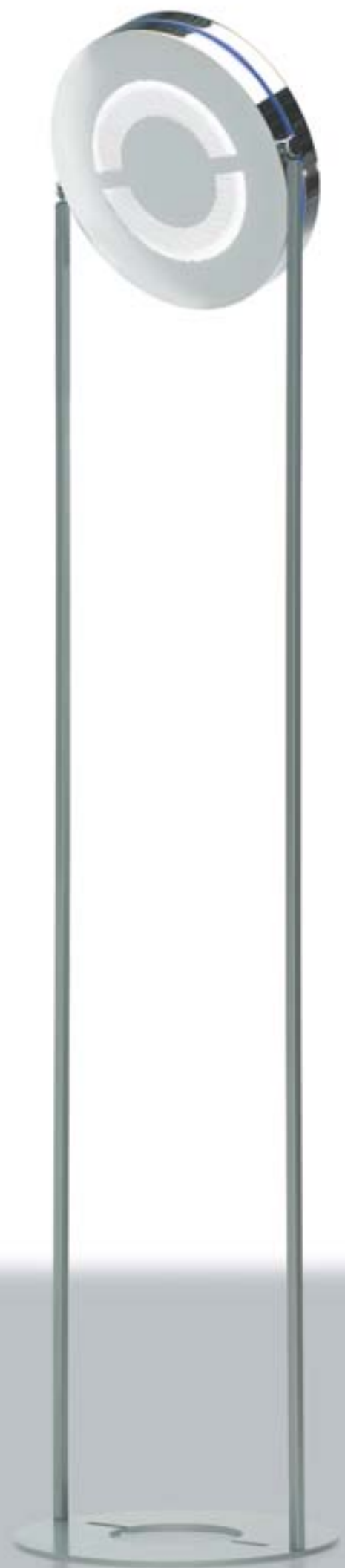





# FLAT-R

design Roberto Favaretto

**Struttura in metallo diffusore in PMMA opalino satinato, cornici disponibili in: bianco, grigio verniciato, nickel spazzolato e cromo lucido. Sospensioni a biemissione. Alimentazione elettronica.**

Metal structure, PMMA satin opal acrylic diffuser. The frames are available in white, grey, brushed nickel and polished chrome. Up-and-down light pendant. Electronic ballast.

Structure en métal, diffuseur en PMMA opalin satiné. Cadre disponibles en: blanc et gris laqué, chrome brillant et nickel brossé. Suspension avec biemission. Ballast électronique.

Struktur aus Metall, weiß PMMA diffuser. Rahmen in vier verschiedenen Ausführungen. Weiß und Grau lackiert, glänzend verchromt und Nickel gebürstet. Bi-emission pendenteuchten. Elektronische Stromversorgung.

Estructura de metal, difusor de PMMA opalino. Marcos disponibles en: blanco o gris barnizado, cromo brillo y níquel cepillado. Colgante con doble emisión. Ballast electrónico.

Металлическое основание представлено в белом, сером цветах, никеле или хrome. Электронный балласт.

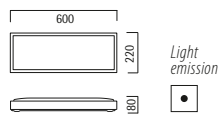

Lampada da soffitto/parete - Ceiling/wall lamp

- 007280** Bianco - White
- 007281** Grigio - Grey
- 007282** Nickel spazzolato - Brushed nickel
- 007283** Cromo - Chrome

G5 2x24W T5

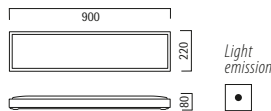

Lampada da soffitto/parete - Ceiling/wall lamp

- 007284** Bianco - White
- 007285** Grigio - Grey
- 007286** Nickel spazzolato - Brushed nickel
- 007287** Cromo - Chrome

G5 2x39W T5

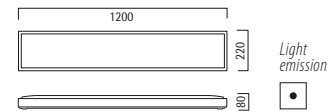

Lampada da soffitto/parete - Ceiling/wall lamp

- 007290** Bianco - White
- 007291** Grigio - Grey
- 007292** Nickel spazzolato - Brushed nickel
- 007293** Cromo - Chrome

G5 2x54W T5

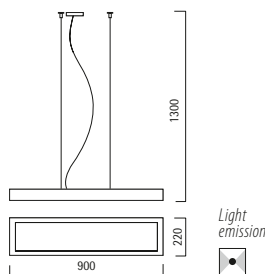
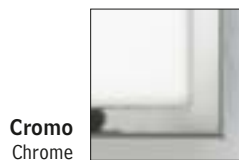
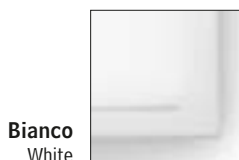

Lampada sospensione - Pendant lamp

- 007352** Bianco - White
- 007353** Grigio - Grey
- 007351** Nickel spazzolato - Brushed nickel
- 007350** Cromo - Chrome

G5 2x39W T5

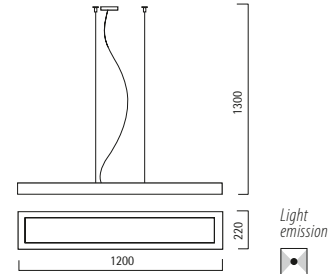

Lampada sospensione - Pendant lamp

- 007356** Bianco - White
- 007357** Grigio - Grey
- 007355** Nickel spazzolato - Brushed nickel
- 007354** Cromo - Chrome

G5 2x54W T5







# FLAT-R





FLAT-R





# FLAT-Q

design Roberto Favaretto

**Struttura in metallo, diffusore in PMMA opalino satinato. Cornici disponibili nelle finiture: bianco, grigio verniciato, nickel spazzolato e per le dimensioni 150x150, 300x300 e 450x450 anche in cromo lucido. Alimentazione elettronica.**

Metal structure, PMMA opal satin acrylic diffuser. The frames are available in white, grey and brushed nickel. The polished chrome option is only available for the frames sizing 150x150, 300x300 and 450x450. Electronic ballast.

Structure en métal, diffuseur en PMMA opalin satiné. Cadre disponibles en: blanc et gris laqué et nickel brossé. Cadre pour le dimensions 150x150, 300x300 et 450x450 disponible aussi chrome brillant. Ballast électronique.

Struktur aus Metall, PMMA diffuser. Rahmen in verschiedenen Ausführungen. Weiß und Grau lackiert, Nickel gebürstet. Die Rahmen 150x150, 300x300 und 450x450 sind auch in glänzend verchromt. Elektronische Stromversorgung.

Estructura de metal barnizado blanco, difusor de PMMA opalino. Marcos disponibles en: blanco o gris barnizado, níquel cepillado. Marco 150x150, 300x300 y 450x450 es disponible en cromo brillo. Ballast electrónico.

Металлическое основание представлено в белом, сером цветах, никеле или хrome. Версия 600x600мм в хrome не производится. Рассеиватель из акрила. Электронный балласт.

**La serie è disponibile nella versione in emergenza da 1H o da 3H. The range is available with emergency working 1H or 3H.**

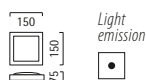

Lampada da soffitto/parete - Ceiling/wall lamp

- 007260** Bianco - White
  - 007261** Grigio - Grey
  - 007262** Nickel spazzolato - Brushed nickel
  - 007263** Cromo - Chrome
- GR10q 1x10W TC-DDE
- CE

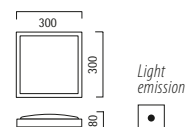

Lampada da soffitto/parete - Ceiling/wall lamp

- 007256** Bianco - White
  - 007257** Grigio - Grey
  - 007258** Nickel spazzolato - Brushed nickel
  - 007259** Cromo - Chrome
- 2G11 2x18W TC-L
- CE

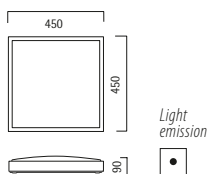

Lampada da soffitto/parete - Ceiling/wall lamp

- 007246** Bianco - White
  - 007247** Grigio - Grey
  - 007248** Nickel spazzolato - Brushed nickel
  - 007249** Cromo - Chrome
- 2G11 3x36W TC-L
- CE

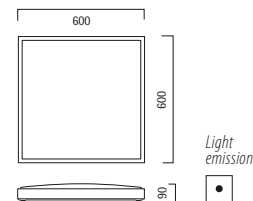

Lampada da soffitto/parete - Ceiling/wall lamp

- 007272** Bianco - White
  - 007273** Grigio - Grey
  - 007274** Nickel spazzolato - Brushed nickel
- 2G11 3x55W TC-L
- CE

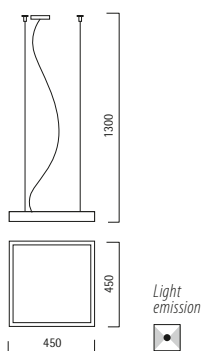

Lampada sospensione - Pendant lamp

- 007362** Bianco - White
  - 007363** Grigio - Grey
  - 007361** Nickel spazzolato - Brushed nickel
  - 007360** Cromo - Chrome
- 2G11 3x36W TC-L
- CE

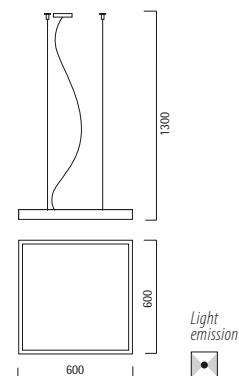

Lampada sospensione - Pendant lamp

- 007366** Bianco - White
  - 007367** Grigio - Grey
  - 007365** Nickel spazzolato - Brushed nickel
- 2G11 3x55W TC-L
- CE









# FLAT-Q



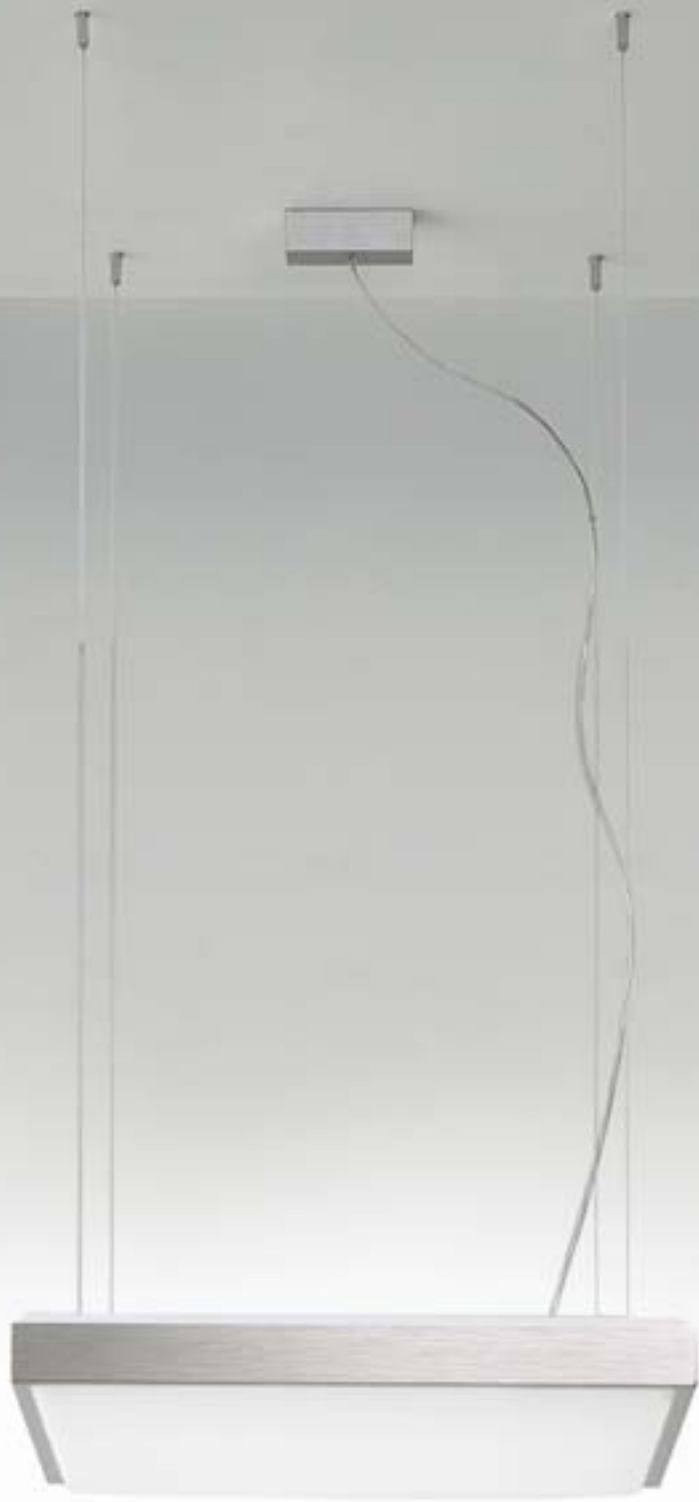

# ZERO-EQUAL

design Roberto Favaretto

**Struttura in metallo, diffusore in vetro serigrafato, cornici disponibili in: bianco e grigio verniciato, cromo lucido e nickel spazzolato. Alimentazione elettronica.**

Metal structure and silk-screened glass diffuser. Frames available in: white and grey painted, glossy chrome and brushed nickel. Electronic ballast.

Structure en métal, diffuseur en verre sérigraphié, cadres disponibles en: blanc et gris laqué, chrome brillant et nickel brossé. Ballast électronique.

Struktur aus Metall, Glasdiffusor mit Siebdruck, Rahmen in: Weiß und Grau lackiert, glänzend verchromt und Nickel gebürstet. Elektronische Stromversorgung.

Estructura de metal, difusor de vidrio serigrafiado, marcos disponibles en: blanco o gris barnizado, cromo brillo y níquel cepillado. Ballast electrónico.

Рассеиватель из стекла. Металлический корпус белого или серого цветов или в хроме или никеле. Так же представлены варианты с 1-часовым или 3-часовым аварийными режимами работы. Электронный балласт.



**La serie è disponibile nella versione in emergenza da 1H o da 3H. The range is available with emergency working 1H or 3H.**



## Zero

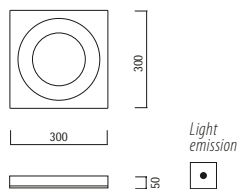

Lampada da soffitto/parete - Ceiling/wall lamp

**015253** Nickel spazzolato - Brushed nickel  
**015252** Cromo - Chrome  
**015251** Grigio - Grey  
**015250** Bianco - White

2GX13 1x22W T5c

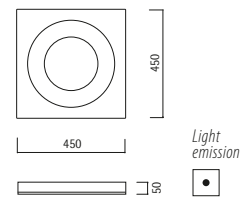

Lampada da soffitto/parete - Ceiling/wall lamp

**015257** Nickel spazzolato - Brushed nickel  
**015256** Cromo - Chrome  
**015255** Grigio - Grey  
**015254** Bianco - White

2GX13 1x55W T5c



## Equal

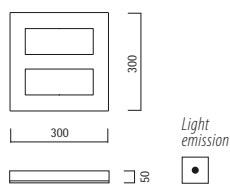

Lampada da soffitto/parete - Ceiling/wall lamp

**015288** Nickel spazzolato - Brushed nickel  
**015289** Cromo - Chrome  
**015290** Grigio - Grey  
**015291** Bianco - White

2G11 2x18W TC-L

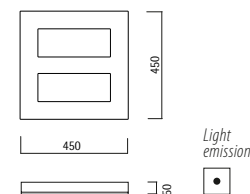

Lampada da soffitto/parete - Ceiling/wall lamp

**015292** Nickel spazzolato - Brushed nickel  
**015293** Cromo - Chrome  
**015294** Grigio - Grey  
**015295** Bianco - White

2G11 2x24W TC-L







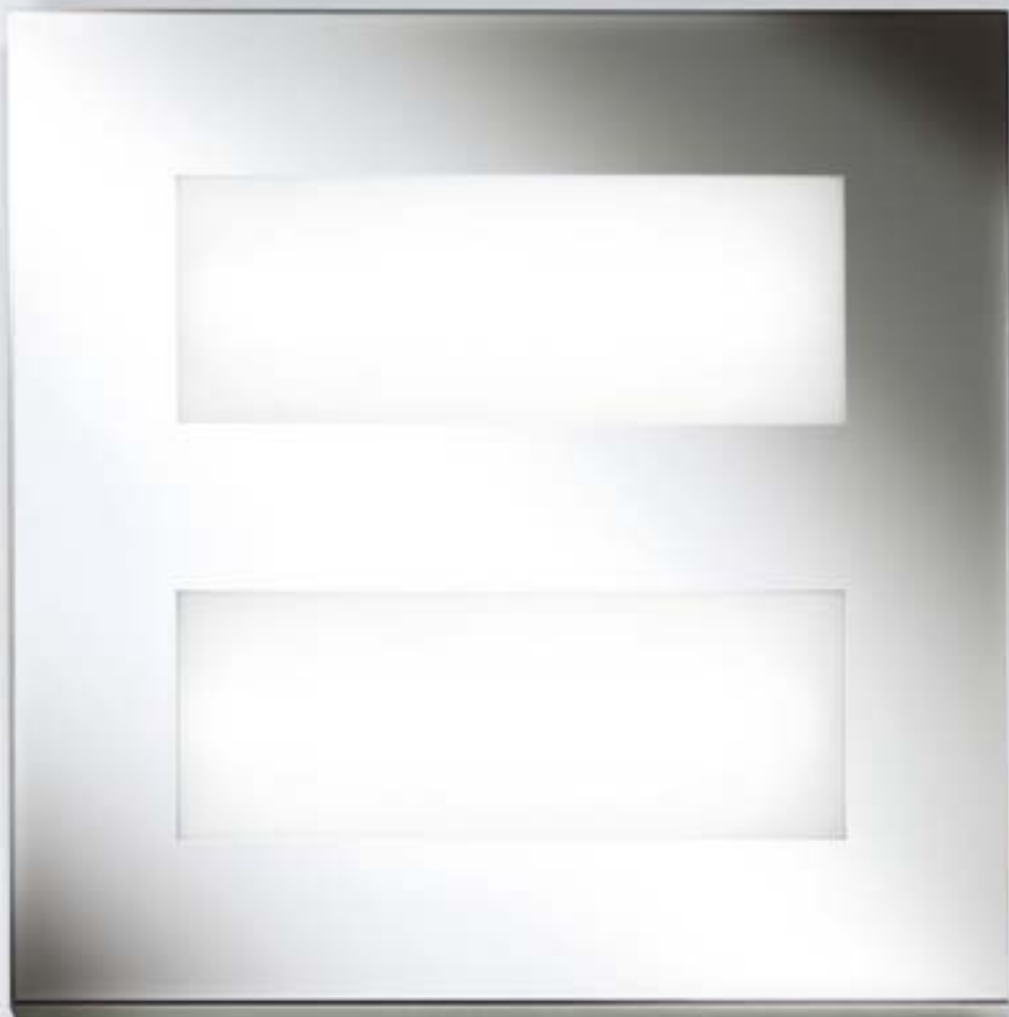

# ZEN

design Roberto Favaretto

**Struttura in metallo verniciato alluminio lucido. Diffusore in vetro curvato. Struttura metallica cromata o nickel spazzolato. Alimentazione elettronica.**

Polished aluminium-painted metal structure. Curved glass diffuser. Chrome or brushed nickel metal structure. Electronic ballast.

Structure en métal peint aluminium brillant. Diffuseur en verre courbé. Structure métallique chromée ou nickel brossée. Ballast électronique.

Struktur aus hochglanzlackiertem oder vernickeltem Metall in Aluminiumausführung. Rechteckiger Lichtverteiler aus geschwungenem Glas. Am Lichtverteiler angebrachte verchromte Metallstruktur. Elektronische Stromversorgung.

Estructura en metal lacado aluminio brillo. Difusor en vidrio curvado. Estructura aplicada al difusor en metal cromado o níquel cepillado. Ballast electrónico.

Металлическое основание. Гнутое стекло. Рамка в хроме или никеле. Электронный балласт.

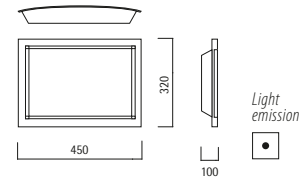

Lampada da soffitto - Ceiling lamp

**013550** Cromo - Chrome  
**013551** Nickel spazzolato - Brushed nickel  
 2G10 2x24W TC-F   
 CE

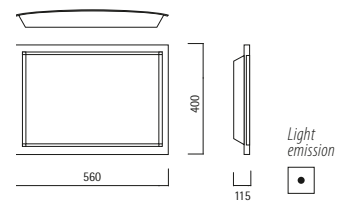

Lampada da soffitto - Ceiling lamp

**013643** Cromo - Chrome  
**013642** Nickel spazzolato - Brushed nickel  
 2G10 2x36W TC-F   
 CE

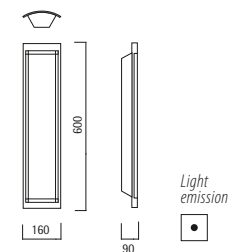

Lampada da parete/soffitto - Wall/Ceiling lamp  
 Cromo - Chrome

G9 4x20W QT-13 **013524**  
 2G11 1x36W TC-L **013545**

Nickel spazzolato - Brushed nickel

G9 4x20W QT-13 **013579**  
 2G11 1x36W TC-L **013546**  
 CE















# VISION

design Roberto Favaretto

**Diffusore in doppio vetro curvato.  
Struttura metallica cromata  
o nickel spazzolato.**

Double curved glass diffuser.  
Chromed or brushed nickel metal structure.

Diffuseur à double verre courbé.  
Structure métallique en métal chromé  
ou nickel brossé.

Rechteckiger Lichtverteiler aus  
doppeltem geschwungenem Glas. An  
den Lichtverteiltern angebrachte verchromte  
oder gebürstete und vernickelte.

Difusor con doble vidrio curvado.  
Estructura metálica cromada o níquel cepillado.

Рассеиватели из гнутого стекла.  
Металлическое основание в хроме  
или никеле.

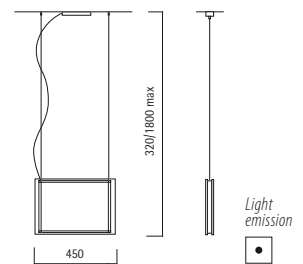

Lampada sospensione - *Pendant lamp*

**009094** Cromo - *Chrome*

**013611** Nickel spazzolato - *Brushed nickel*

R7s 118mm 1x120W QT-DE

CE

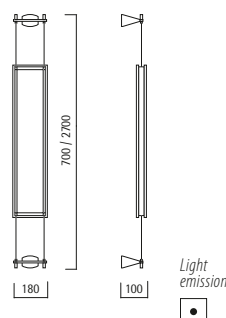

Lampada da parete - *Wall lamp*

**013588** Cromo - *Chrome*

**013608** Nickel spazzolato - *Brushed nickel*

E27 2x70W A55

E27 2x70W QT-32

E27 2x24W TC-TSE

CE

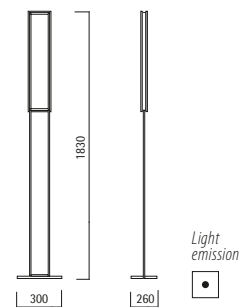

Lampada da terra - *Floor lamp*

**058580** Cromo - *Chrome*

**013612** Nickel spazzolato - *Brushed nickel*

E27 2x70W A55

E27 2x70W QT-32

E27 2x24W TC-TSE

CE

**Cromo**  
Chrome



**Nickel spazzolato**  
Brushed nickel







VISION





# AGAVE

design Roberto Favaretto

## Diffusore opale e trasparente in vetro soffiato. Struttura in metallo cromato.

Opal and transparent blown glass diffuser.  
Chrome metal structure.

Diffuseur opale et transparent en verre soufflé.  
Structure en métal chromé.

Geblasenem opal und transparentem Glas.  
Struktur aus verchromtem Metall.

Difusor opal y transparente en vidrio soplado.  
Estructura en metal cromado.

Плафоны из дутого стекла.  
Хромированное металлическое основание.

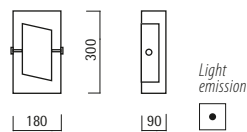

Lampada da parete - *Wall lamp*  
Vetro opale - *Opal glass*

**013103**

R7s 78mm 1x80W QT-DE 

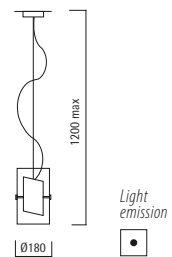

Lampada sospensione - *Pendant lamp*  
Vetro opale - *Opal glass*

**013112**

E27 1x70W A55   
E27 1x14W TC-TSE 



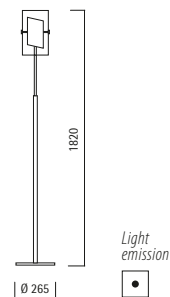

   



Lampada da terra - *Floor lamp*  
Vetro opale - *Opal glass*

**013162**

E27 1x205W QT-32   
E27 1x14W TC-TSE 

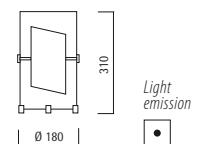

Lampada da tavolo - *Table lamp*  
Vetro opale - *Opal glass*

**013011**

E27 1x70W A55   
E27 1x14W TC-TSE 

**Cromo**  
Chrome







AGAVE



**Diffusore in ceramica bone china bianca con texture a rilievo. Struttura in pressofusione verniciata grigia.**

White bone china lamp with relief texture.  
Grey painted metal structure.

Diffuseur en porcelaine tendre blanche avec texture en relief. Structure en zamak moulé sous pression laquée grise.

Licht aus weißem Bone China Porzellan mit Relieftextur. Struktur aus Druckguss-Zamak, grau lackierte.

Difusor de cerámica bone china blanca, con textura en relieve. Estructura de zamak fundido en presión, barnizada gris.

Рельефный плафон из фарфора.  
Металлическое основание

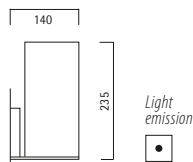

Lampada da parete - *Wall lamp*  
Diffusore ceramica bone china bianca  
*White bone china diffuser*

**014050**

E27 1x70W A55

E27 1x21W TC-TSE

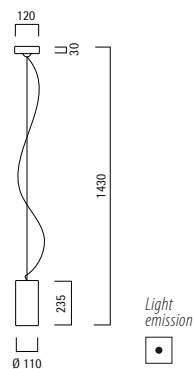

Lampada sospensione - *Pendant lamp*  
Diffusore ceramica bone china bianca  
*White bone china diffuser*

**014051**

E27 1x52W A55

E27 1x21W TC-TSE

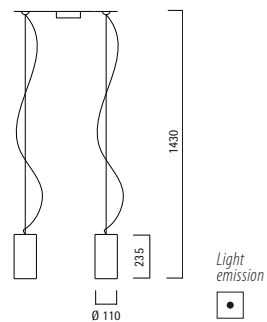

Lampada sospensione - *Pendant lamp*  
Diffusore ceramica bone china bianca  
*White bone china diffuser*

**014052**

E27 2x52W A55

E27 2x21W TC-TSE

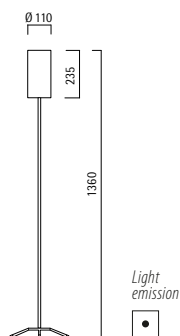

Lampada da terra - *Floor lamp*  
Diffusore ceramica bone china bianca  
*White bone china diffuser*

**014053**

E27 1x70W A55

E27 1x21W TC-TSE

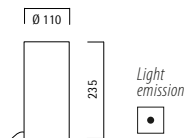

Lampada da tavolo - *Table lamp*  
Diffusore ceramica bone china bianca  
*White bone china diffuser*

**014054**

E27 1x70W A55

E27 1x21W TC-TSE

**Bianco**  
White







NIPPO







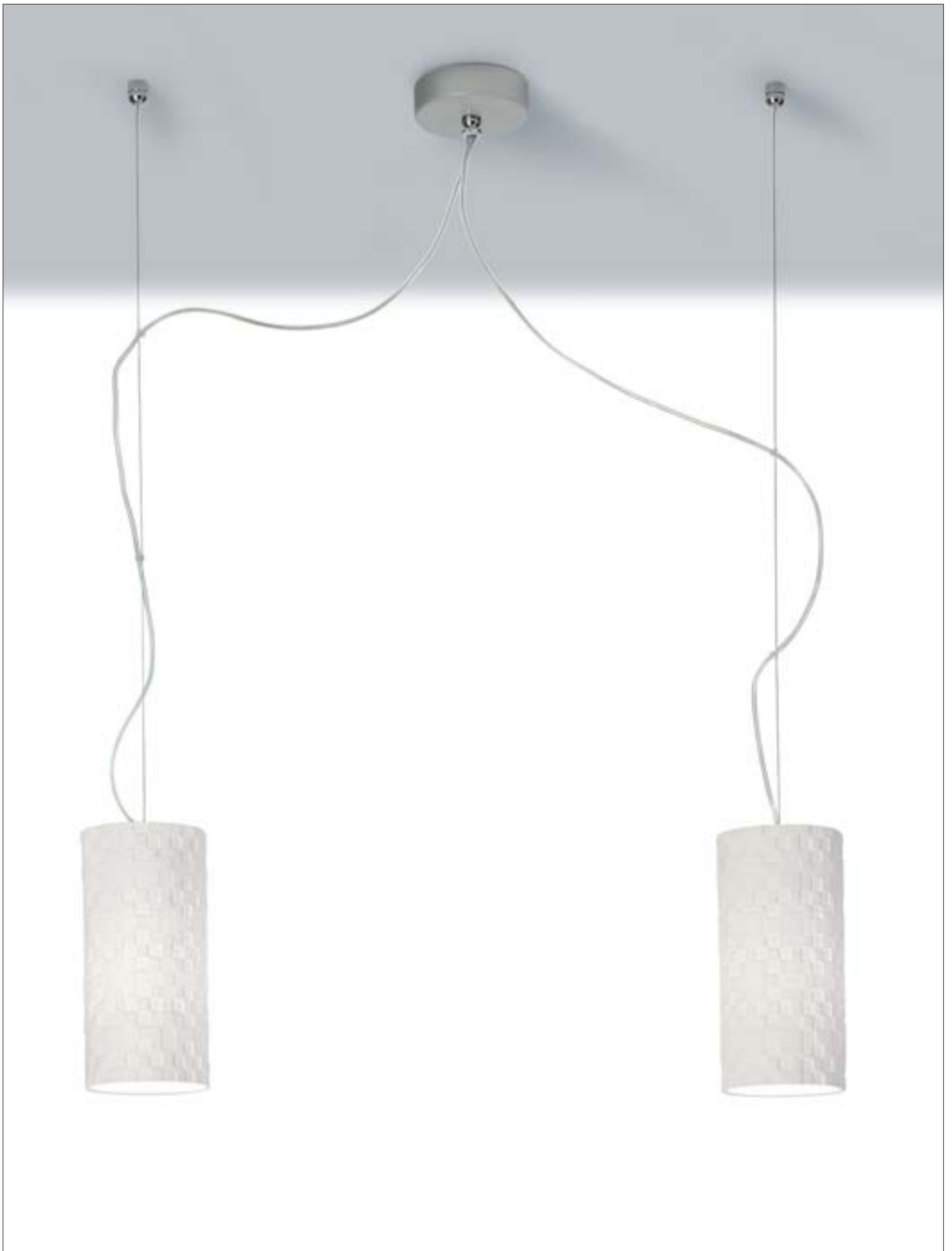





# FLORA

design Roberto Favaretto

**Diffusore in vetro soffiato satinato:  
opale, cobalto, ambra e arancio.  
Struttura in metallo cromato.**

Satin blown glass: opal, cobalt blue, amber and orange. Chrome metal structure.

Diffuseur en verre soufflé: opale, cobalt, ambre et orange. Structure en métal chromé.

Gebblasenem Glas: Opal, Kobalt, Bernstein und Orange. Struktur aus verchromtem Metall.

Difusor en vidrio soplado satinado: opal, cobalto, àmbar y naranja. Estructura en metal cromado.

Плафоны из дутого стекла в белом, синем, зеленом, песочном или оранжевом цветах.

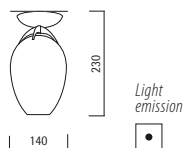

Lampada da soffitto - Ceiling lamp

- 009204** Opale satinato - *Satin opal*
- 009206** Cobalto satinato - *Satin cobalt blue*
- 009209** Ambra satinato - *Satin amber*
- 009208** Arancio satinato - *Satin orange*

E14 1x42W P45

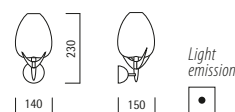

Lampada da parete - Wall lamp

- 010237** Opale satinato - *Satin opal*
- 010238** Cobalto satinato - *Satin cobalt blue*
- 010241** Ambra satinato - *Satin amber*
- 010239** Arancio satinato - *Satin orange*

E14 1x42W P45

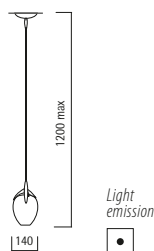

Lampada sospensione - Pendant lamp

- 009077** Opale satinato - *Satin opal*
- 009078** Cobalto satinato - *Satin cobalt blue*
- 009083** Ambra satinato - *Satin amber*
- 009079** Arancio satinato - *Satin orange*

E14 1x42W P45

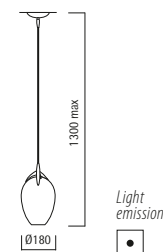
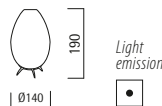

Lampada sospensione - Pendant lamp

- 009015** Opale satinato - *Satin opal*
- 009018** Cobalto satinato - *Satin cobalt blue*
- 009021** Ambra satinato - *Satin amber*
- 009019** Arancio satinato - *Satin orange*

E27 1x52W A55

E27 1x24W TC-TSE



**Opale satinato**  
Satin opal



**Cobalto satinato**  
Satin cobalt blue



**Ambra satinato**  
Satin amber



**Arancio satinato**  
Satin orange



Lampada da tavolo - Table lamp

- 009057** Opale satinato - *Satin opal*
- 009058** Cobalto satinato - *Satin cobalt blue*
- 009062** Ambra satinato - *Satin amber*
- 009059** Arancio satinato - *Satin orange*

E14 1x42W P45

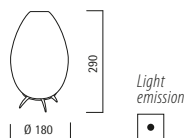

Lampada da tavolo - Table lamp

- 009080** Opale satinato - *Satin opal*
- 009081** Cobalto satinato - *Satin cobalt blue*
- 009084** Ambra satinato - *Satin amber*
- 009082** Arancio satinato - *Satin orange*

E27 1x70W A55

E27 1x24W TC-TSE

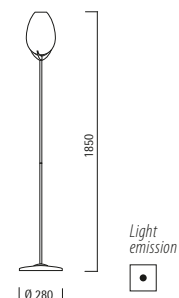

Lampada da terra - Floor lamp

- 009128** Opale satinato - *Satin opal*
- 009129** Cobalto satinato - *Satin cobalt blue*
- 009131** Ambra satinato - *Satin amber*
- 009130** Arancio satinato - *Satin orange*

E27 1x205W QT-32

E27 1x24W TC-TSE







FLORA





# SPACE

design Afra e Tobia Scarpa 2001

**Diffusore in vetro satinato sabbato.**  
**Supporto di appoggio del vetro in lamiera stampata e verniciata alluminio lucido.**  
**Finali di fissaggio del diffusore in termoplastico forniti nei colori: trasparente, acquamare, giallo e rosso.**

Sanded satin glass diffuser. Polished aluminium painted support. Thermoplastic diffuser fasteners available in: clear, aqua, yellow and red.

Diffuseur en verre satiné sablé. Support peint aluminium brillant. Eléments de fixation du diffuseur en matériel thermoplastique, interchangeables et fournis dans les coloris: transparent, aigue-marine, jaune et rouge.

Lichtverteiler aus satiniertem, sandgestrahltem Glas.  
 Endelemente zur Befestigung des Lichtverteilers aus thermoplastischem Material, in den Farben: Transparent, Meerwasser, Gelb und Rot lieferbar.

Lámpara de techo o suspensión con luz difusa.  
 Difusor en vidrio arenado. Soporte en chapa prensada, lacada aluminio brillo. Fijadores del difusor en termoplástico provistos en los colores: transparente, agua marina, amarillo y rojo.

Рассеиватель из матового стекла. Крепежи из термопластика прозрачного, желтого, красного цветов или цвета морской волны. прикосновением.

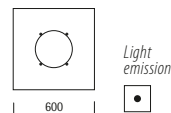
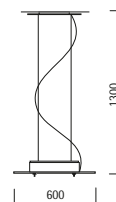

Lampada sospensione - *Pendant lamp*  
 Vetro satinato - *Satin glass*

**013591**

R7s 118mm 1x120W QT-DE

G9 1x33W QT-13 Lampadina superiore - *Top lamp*

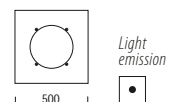

Lampada da soffitto/parete - *Ceiling/wall lamp*  
 Vetro satinato - *Satin glass*

**010037**

R7s 118mm 1x120W QT-DE





# SPACE

design Afra e Tobia Scarpa 2001



# JAZZ

design Roberto Favaretto

**Diffusore in vetro soffiato trasparente satinato. Struttura metallica cromata.**

Satin transparent blown glass diffuser.  
Chromed metal structure.

Diffuseur en verre soufflé transparent satiné.  
Structure métallique chromée.

Lichtverteiler aus geblasenem, transparentem,  
satinierem Glas. Metallstruktur verchromt.

Difusor en vidrio soplado transparente satinado.  
Estructura metálica cromada.

Частично матированный плафон из дутого  
стекла. Металлическое основание в хроме.

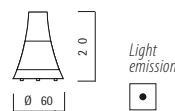

Lampada da tavolo - Table lamp

**019589** Cromo - Chrome

E14 1x42W P45

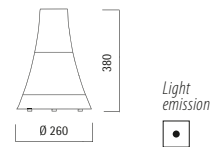

Lampada da tavolo - Table lamp

**019588** Cromo - Chrome

E27 1x70W A55

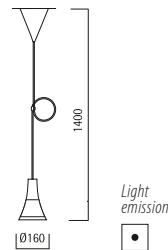

Lampada sospensione - Pendant lamp

**019617** Cromo - Chrome

E14 1x42W P45

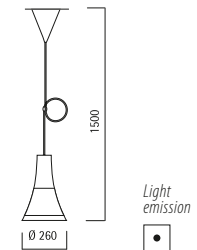

Lampada sospensione - Pendant lamp

**019597** Cromo - Chrome

E27 1x70W A55

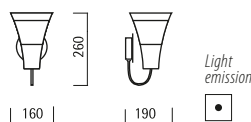

Lampada da parete - Wall lamp

**019596** Cromo - Chrome

E14 1x42W P45

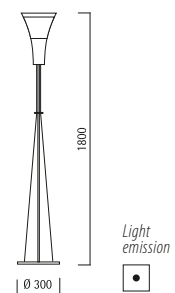

Lampada da terra - Floor lamp

**019598** Cromo - Chrome

E27 1x205W QT-32

**Cromo**  
Chrome







JAZZ





# BLUES

design Roberto Favaretto

**Diffusore in vetro soffiato  
trasparente satinato. Struttura  
in metallo nickel spazzolato.**

Satin blown glass diffuser.  
Brushed nickel metal structure.

Diffuseur en verre soufflé transparent satiné.  
Structure en nickel brossé.

Lichtverteiler aus geblasenem, transparentem,  
satinierem Glas. Struktur aus verchromtem Metall.

Difusor en vidrio soplado transparente satinado.  
Estructura metálica en níquel cepillado.

Частично матированный плафон из дутого  
стекла. Металлическое основание.

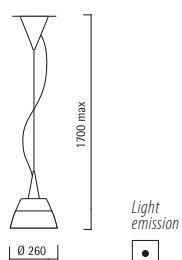

Lampada sospensione - *Pendant lamp*

**019626** Nickel spazzolato - *Brushed nickel*

E27 1x70W A55

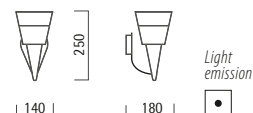

Lampada da parete - *Wall lamp*

**019505** Nickel spazzolato - *Brushed nickel*

E14 1x42W P45

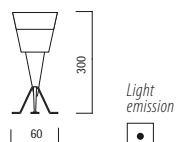

Lampada da tavolo - *Table lamp*

**019628** Nickel spazzolato - *Brushed nickel*

E14 1x42W P45

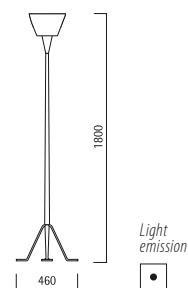

Lampada da terra - *Floor lamp*

**019625** Nickel spazzolato - *Brushed nickel*

E27 1x205W QT-32

**Nickel spazzolato**  
Brushed nickel







BLUES

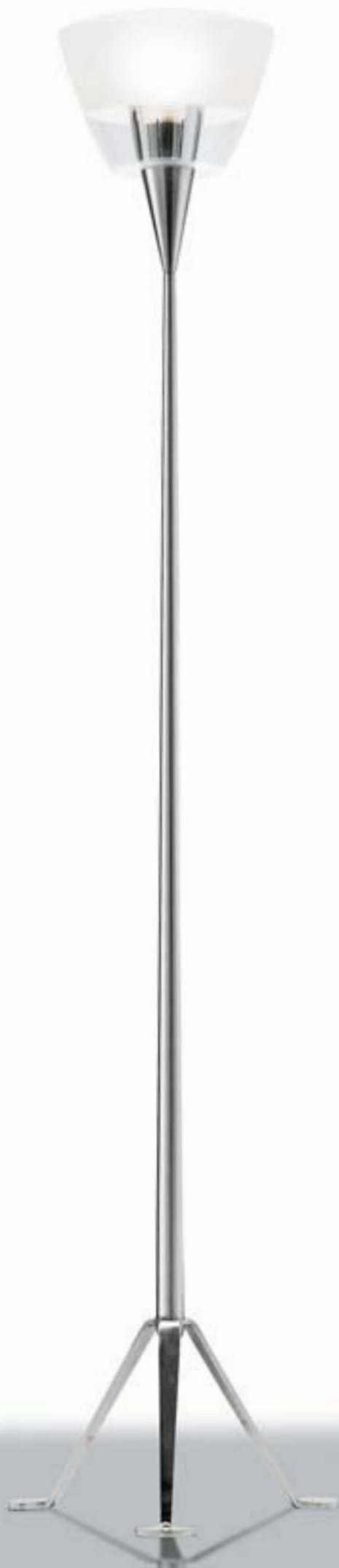

# CLETO

design Roberto Favaretto

**Struttura in alluminio. Filtri decorativi intercambiabili in policarbonato colorati: ghiaccio, blu e giallo.**

Structure made of aluminium.  
Removable, decorative polycarbonate filters in ice-blue, blue and yellow.

Structure en aluminium.  
Filtres décoratifs interchangeable colorés en polycarbonate: glacier, bleu et jaune.

Struktur aus Aluminium. Austauschbare Dekorfilter aus farbigem Polycarbonat: Eis, Blau und Gelb.

Estructura en aluminio.  
Filtros decorativos intercambiables en policarbonato colorados: satinado, azul y amarillo.

Алюминиевое основание.  
Снимаемые декоративные фильтры из поликарбоната голубого, синего или желтого цветов.

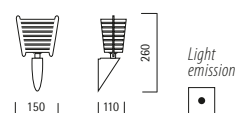

Lampada da parete - *Wall lamp*  
**019023** Alluminio - *Aluminium*  
E27 1x52W A55   
CE

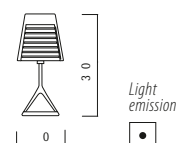

Lampada da tavolo - *Table lamp*  
**019022** Alluminio - *Aluminium*  
E14 1x28W P45   
CE





CLETO





# TRATTO

design Lucente Lab

## Struttura in metallo cromato opaco. Diffusore in vetro soffiato opale satinato.

Mat chromed metal structure.  
Opal satin blown glass diffuser.

Structure en métal chromé mat.  
Diffuseur en verre soufflé opale satiné.

Struktur aus matt verchromtem Metall.  
Lichtverteiler aus geblasenem,  
satiniertem Opalglas.

Estructura en metal cromado opaco.  
Difusor en vidrio soplado opal satinado.

Металлическое основание в хроме.  
Матовое дутое стекло белого цвета.

**Cromo opaco**  
Matt chrome



Lampada da parete - *Wall lamp*

**013589** Cromo opaco - *Matt chrome*

R7s 118mm 1x120W QT-DE 

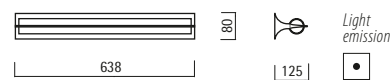

Lampada da parete - *Wall lamp*

**013592** Cromo opaco - *Matt chrome*

G5 1x24W T5 

alimentazione elettronica - *electronic ballast*





TRATTO



# BRICK

design Roberto Favaretto

**Struttura in metallo cromato o nickel spazzolato. Diffusori in vetro verniciato bianco. Alimentazione elettronica.**

Chromed or brushed nickel metal structure. White painted glass diffusers. Electronic ballast.

Structure en métal chromé ou nickel brossé. Diffuseurs en verre opalin avec finition satinée. Ballast électronique.

Struktur aus verchromtem oder Nickel gebürstete Metall. Diffusoren aus Glas, satinierte Ausführung. Elektronische Stromversorgung.

Estructura en metal cromado o níquel cepillado. Doble difusor en vidrio opal satinado. Ballast electrónico.

Металлическое основание в хроме или никеле. Рассеиватель из стекла. Электронный балласт.

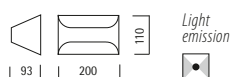

Lampada da parete - Wall lamp

**015430** Cromo - Chrome

**015431** Nickel spazzolato - Brushed nickel

R7s 78mm 1x80W QT-DE

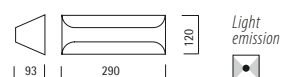

Lampada da parete - Wall lamp

**015436** Cromo - Chrome

**015437** Nickel spazzolato - Brushed nickel

G24d-3 1x26W TC-D

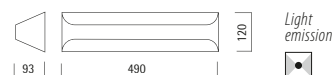

Lampada da parete - Wall lamp

**015438** Cromo - Chrome

**015439** Nickel spazzolato - Brushed nickel

2G11 1x36W TC-L



**Supporto in metallo cromato o nickel spazzolato. Diffusore in vetro satinato.**

Chrome or brushed nickel metal support.  
Satin glass diffuser.

Support en métal chromé ou nickel brossé.  
Diffuseur en verre satiné.



Halterung aus verchromtem oder gebürstetem und  
vernickeltem Metall.  
Lichtverteiler aus satiniertem Glas.

Soporte en metal cromado o níquel cepillado.  
Difusor en vidrio satinado.

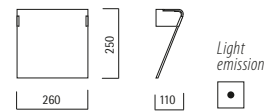

Металлическое основание в хроме или  
никеле. Рассеиватель из матового стекла.



Lampada da parete - Wall lamp  
Cromo - Chrome

R7s 118mm 1x120W QT-DE  **013580**  
G24d-3 1x26W TFC-D  **013581**

Nickel spazzolato - Brushed nickel

R7s 118mm 1x120W QT-DE  **013597**  
G24d-3 1x26W TFC-D  **013598**



**Cromo**  
Chrome



**Nickel spazzolato**  
Brushed nickel

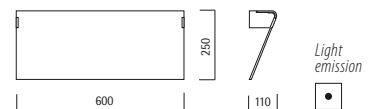

Lampada da parete - Wall lamp  
Cromo - Chrome

R7s 78mm 2x80W QT-DE  **013584**  
2G11 1x36W TC-L  **013585**

Nickel spazzolato - Brushed nickel

R7s 78mm 2x80W QT-DE  **013601**  
2G11 1x36W TC-L  **013602**











# ECO

design Roberto Favaretto

**Riflettore frontale esterno in metallo nickel spazzolato e verniciato bianco all'interno. Alimentazione elettronica.**

The metal reflector is brushed nickel outside and white painted inside. Electronic ballast.

Réflecteur frontal extérieur en métal nickel brossé et laqué blanc à l'intérieur. Ballast électronique.

Frontreflektor außen aus Nickel gebürstetem Metall und innen weißlackiert. Elektronische Stromversorgung.

Reflector frontal exterior de metal níquel cepillado y pintado de blanco en la parte interior. Ballast electrónico.

Металлический отражатель никелирован с внешней стороны, а с внутренней - окрашен в белый цвет. Красный фильтр создает цветной световой эффект. Электронный балласт.

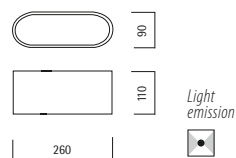

Lampada da parete - Wall lamp

**015520** Nickel spazzolato - *Brushed nickel*  
R7s 78mm 1x80W QT-DE

CE

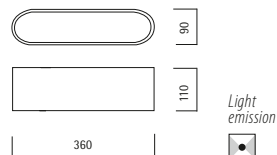

Lampada da parete - Wall lamp

**015522** Nickel spazzolato - *Brushed nickel*  
R7s 78mm 1x120W QT-DE

**015521** Nickel spazzolato - *Brushed nickel*  
G24d-3 1x26W TC-D

CE

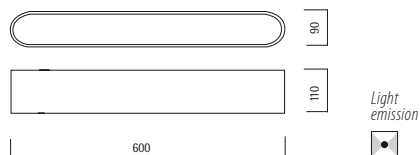

Lampada da parete - Wall lamp

**015526** Nickel spazzolato - *Brushed nickel*  
2G11 1x36W TC-L

CE

**Nickel spazzolato**  
Brushed nickel





# HAPPY

design Roberto Favaretto

**Struttura in metallo microforato  
cromato o nickel spazzolato.  
Diffusore in vetro temperato.**

Micro-perforated metal structure available  
in chrome and brushed nickel.  
Tempered glass diffuser.

Corps de la lampe en tôle micro perforée  
et acier chromé ou nickel brossé.  
Diffuseur en verre tempéré.

Lampenkörper aus perforiertem Blech und  
verchromtem oder gebürstetem  
und vernickeltem Metall. Lichtverteiler aus  
gehärtetem Glas.

Estructura en chapa microperforada y acero cromado  
o níquel cepillado. Difusor en vidrio templado.

Металлическое основание в хроме или никеле.  
Рассеиватель из закаленного стекла.



**Cromo**  
Chrome



**Nickel spazzolato**  
Brushed nickel

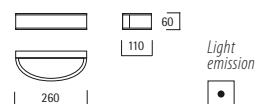

Lampada da parete - Wall lamp

**013569** Cromo - Chrome



































**013574** Nickel spazzolato - Brushed nickel

R7s 78mm 1x80W QT-DE ←→















CE









**Lampade fluorescenti - Fluorescent lamps**

Symbol	Uni	Wattage	Socket	Code
	TC-S	9W	G23	<b>052564</b>
	TC-SE	11W	2G7	<b>052559</b>
	TC-D	13W	G24d-1	<b>052560</b>
	TC-D	18W	G24d-2	<b>052569</b>
	TC-D	26W	G24d-3	<b>052562</b>
	TC-DE	18W	G24q-2	<b>052563</b>
	TC-DE	26W	G24q-3	<b>052565</b>
	TC-DD	16W	GR8	<b>052561</b>
	TC-DD	28W	GR8	<b>052566</b>
	TC-DDE	10W	GR10q	<b>052570</b>
	TC-DDE	28W	GR10q	<b>052567</b>
	TC-DDE	38W	GR10q	<b>052568</b>
	TC-L	18W	2G11	<b>052622</b>
	TC-L	24W	2G11	<b>052621</b>
	TC-L	36W	2G11	<b>052624</b>
	TC-L	55W	2G11	<b>052650</b>
	TC-F	24W	2G10	<b>052604</b>
	TC-F	36W	2G10	<b>052608</b>
	TC-TSE	14W	E27	<b>052630</b>
	TC-TSE	17W	E27	<b>052528</b>
	TC-TSE	21W	E27	<b>052648</b>
	TC-TSE	24W	E27	<b>052638</b>
	TC-TSE	30W	E27	<b>052668</b>
	T16 (T5)	24W	G5	<b>052625</b>
	T16 (T5)	28W	G5	<b>052667</b>
	T16 (T5)	39W	G5	<b>052623</b>
	T16 (T5)	54W	G5	<b>052649</b>
	T5c	22W	2GX13	<b>052639</b>
	T5c	40W	2GX13	<b>052641</b>
	T5c	55W	2GX13	<b>052640</b>
	T-R	22W	G10q	<b>052642</b>
	T-R	32W	G10q	<b>052644</b>
	MICROLYNX_F	7W	GX53	<b>052647</b>
	MICROLYNX_F	9W	GX53	<b>052662</b>

**Lampade alogene - Halogen lamps**

Symbol	Uni	Wattage	Socket	Code
	QT-13	20W	G9	<b>052532</b>
	QT-13	33W	G9	<b>052535</b>
	QT-13	48W	G9	<b>052540</b>
	QT-14	60W	G9	<b>052531</b>
	QT-DE 78mm	80W	R7s	<b>052533</b>
	QT-DE 78mm	120W	R7s	<b>052534</b>
	QT-DE 118mm	120W	R7s	<b>052536</b>
	QT-DE 118mm	160W	R7s	<b>052521</b>
	QT-DE 118mm	230W	R7s	<b>052522</b>
	QPAR	50W	GU10	<b>052530</b>
	QPAR	75W	GU10	<b>052527</b>
	QT-32	70W	E27	<b>052636</b>
	QT-32	100W	E27	<b>052637</b>
	QT-32	205W	E27	<b>052663</b>

**Lampade ad incandescenza - incandescent lamps**

Symbol	Uni	Wattage	Socket	Code
	A55	28W	E27	<b>052665</b>
	A55	42W	E27	<b>052611</b>
	A55	52W	E27	<b>052612</b>
	A55	70W	E27	<b>052602</b>
	A55	105W	E27	<b>052666</b>
	B35	28W	E14	<b>052664</b>
	P45	28W	E14	<b>052609</b>
	P45	42W	E14	<b>052613</b>

Tutti i prodotti di LUCENTE che rientrano nell'ambito di applicazione della direttiva europea EMC 89/336 e 93/68 EEC, soddisfano i requisiti richiesti e recano la marcatura **CE**. Il simbolo **CE** è posto sull'imballo del prodotto.

Nella continua ricerca di miglioramenti tecnici e funzionali, LUCENTE srl si riserva il diritto di apportare modifiche anche sostanziali ai propri prodotti, che potranno essere effettuate senza preavviso. Disegni, quote e colori sono da intendersi a titolo puramente indicativo e non sono impegnative per LUCENTE srl.

Il marchio KIWA è valido in tutto il mondo. Indica che l'azienda ha ottenuto la certificazione aziendale del Sistema di Qualità per quello che riguarda la progettazione, la produzione e la vendita di apparecchi di illuminazione. La norma di riferimento è di UNI EN ISO 9001.

All the products of LUCENTE meet with current European directives EMEC 89/336 and 93/68 EEC, meet their requirements and are **CE** marked. The symbol **CE** is placed on the packaging of the product.

In accordance with its policy of continuous products development LUCENTE reserves the right to modify its products without prior notice. Descriptions, charges and colours in this catalogue are indicative.

The Certificate KIWA is valid all over the world. It is there indicated that the company has obtained the Quality System Certificate for what concerns specification, production and distribution of lighting products. The regulation standard is UNI EN ISO 9001.



**Certificato / Certificate n. KI-050168/01**  
(sistema qualità certificato / quality system UNI EN ISO 9001:2000)

## Protection degree

**IP20:** Protezione contro l'ingresso di corpi solidi  $\varnothing \geq 12\text{mm}$   
Protected against the penetration of solid bodies  $\varnothing \geq 12\text{mm}$

**IP30:** Protezione contro l'ingresso di corpi solidi  $\varnothing \geq 2,5\text{ mm}$   
Protected against the penetration of solid bodies  $\varnothing \geq 2,5\text{mm}$

**IP40:** Protezione contro l'ingresso di corpi solidi  $\varnothing \geq 1\text{mm}$   
Protected against the penetration of solid bodies  $\varnothing \geq 1\text{mm}$

**IP44:** Protezione contro l'ingresso di corpi solidi  $\varnothing \geq 1\text{mm}$   
e contro gli spruzzi  
Protected against the penetration of solid bodies  $\varnothing \geq 1\text{mm}$   
and against the squeezes

## Approvals

**CE** Certificazione di conformità europea  
Certification of European conformity

**F** Apparecchio idoneo al montaggio su superfici infiammabili  
Luminaire suitable for installation on inflammable surfaces

**PC** GOST  
Certificazione di conformità valida per la Federazione Russa  
Certification for Russian Federation

## Class

 Classe I - Class I - Classe I - Klasse I - Classe I

Apparecchio nel quale la sicurezza elettrica è garantita da un conduttore supplementare di protezione (messa a terra) collegato alla struttura metallica della lampada.

A light fitting whose safety is guaranteed by an additional protective conductor (earth) connected with the metal frame of the lamp.

 Classe II - Class II - Classe II - Klasse II - Classe II

Apparecchio nel quale la protezione contro la scossa elettrica si basa unicamente sul doppio isolamento e/o isolamento rinforzato in ogni parte e senza dispositivo di messa a terra.

Light fittings whose safety is guaranteed by the double reinforced insulation of conductive parts, with no earth.

## Light emission



Diffondente  
Diffused



Diretta  
Direct



Indiretta  
Indirect



Diretta e indiretta  
Direct and indirect



Orientabile  
Adjustable



## Direttiva RAEE: Rifiuti di Apparecchiature Elettriche ed Elettroniche

Il 25 Luglio 2005 il Consiglio dei Ministri ha recepito con Decreto Legislativo no 151 la Direttiva Europea 2002/95/CE e 2002/96/CE relativa alla riduzione delle sostanze pericolose nelle apparecchiature elettriche ed elettroniche e dello smaltimento dei rifiuti da essi derivanti. L'obiettivo è promuovere una logica di sviluppo sostenibile nel settore delle apparecchiature elettriche ed elettroniche, di cui gli apparecchi di illuminazione ne fanno parte, ai fini di un corretto trattamento dei prodotti a fine vita e ciò può attuarsi attraverso la piena conformità alla Direttiva RAEE. Il Produttore, come definito dal Dlgs no 151, dovrà farsi carico dei costi di gestione che comprendono la raccolta, presso gli impianti di stoccaggio provvisorio e dello smaltimento dei rifiuti degli apparecchi di illuminazione immessi sul mercato dopo l'Agosto 2006. Per adempiere a questi obblighi di legge LUCENTE S.r.l. ha deciso di avvalersi del supporto del Consorzio ECOLIGHT, Via Gattamelata 34, 20149 Milano Tel 02 33600732.



Gli apparecchi di illuminazione saranno marcati in modo da identificare il Produttore e riportare il simbolo del cassonetto barrato, indicante la raccolta differenziata separata dal resto dei rifiuti urbani, inoltre saranno soggetti al contributo di smaltimento, differenziato per fascia di peso. Gli utenti finali potranno consegnare i suddetti apparecchi senza costi aggiuntivi presso i punti di raccolta appositamente realizzati e comunicati dal Consorzio. I distributori sono obbligati ad assicurare al momento della fornitura di una nuova apparecchiatura, il ritiro gratuito, in ragione di uno ad uno, della apparecchiatura usata. L'obbligo di informazione relativo al contributo dovrà essere mantenuto visibile in fattura, da parte del Produttore, fino al 13 febbraio 2011.

I prodotti elencati con il relativo peso netto alla fine del presente catalogo saranno soggetti al contributo di smaltimento a seconda della fascia di peso di appartenenza:

- fascia 1: apparecchi il cui peso è compreso tra 0 e 2 Kg
- fascia 2: apparecchi il cui peso è compreso tra 2 e 8 Kg
- fascia 3: apparecchi il cui peso è superiore a 8 Kg

### Direttiva RoHS

Il Decreto Legislativo sopra menzionato incorpora anche la Direttiva 2002/95/CE - RoHS - Limiti d'uso di alcune sostanze pericolose - relativa alla riduzione delle sostanze pericolose nelle apparecchiature elettriche ed elettroniche.

A partire dal 1° Luglio 2006 tutte le nuove apparecchiature elettriche ed elettroniche immesse sul mercato non dovranno contenere o contenere in misura limitata sostanze quali: Piombo, Mercurio, Cadmio, Cromo esavalente, Bifenile polibromurati (PBB), Eteri difenilbromurati (PBDE).

## WEEE Directive: Waste Electrical and Electronic Equipment

On the 25th July 2005, the Council of Ministers incorporated the European Directive 2002/95/CE and 2002/96/CE – related to the reduction of hazardous substances in electronic and electrical equipment and their waste disposal - into Italian legislation with the Legislative Decree number 151. The objective is that of promoting a notion of sustainable development within the electronic and electrical equipment sector, to which lighting equipment belongs, with the aim of correctly treating the products once they have reached the end of their lives; this may be accomplished by fully complying with the WEEE Directive. The Manufacturer, as defined by the Legislative Decree number 151, will be responsible for the management costs which include collection from temporary storage facilities and the costs for waste disposal of the lighting Equipment. In order to fulfil these legal obligations LUCENTE S.r.l. have decided to call upon the support of the ECOLIGHT Consortium; Consorzio ECOLIGHT, Via Gattamelata 34, 20149 Milan Tel. +39 02 3360 0732.



The lighting equipment will be marked in such a way as to identify the Manufacturer and show the symbol of the crossed wheeled bin, which indicates a separate collection from the rest of the urban waste, the equipment will also be subject to a disposal contribution and will be distinguishable by its weight range. The contribution will be determined prior to the law coming into force and will be made official by the ECOLIGHT Consortium. The end users will be able to deliver the above-mentioned equipment without any add-on costs to the authorised collection sites as notified by the Consortium. Distributors are obliged to ensure a free take-back service of the used equipment, at the time of the supply of a new unit, on a one-to-one basis. The Manufacturer has a duty to supply and maintain information related to the amount of contribution and this must be shown on invoices until 13th February 2011.

The products listed in this catalogue will be marked with range symbols. Each symbol should be shown against its relevant range within the following table and each range will be subject to a different disposal contribution:

- range 1: the equipment weight which is between 0 and 2 kg
- range 2: the equipment weight which is between 2 up to 8kg
- range 3: the equipment weight which is over 8kg

### The RoHS Directive

The above-mentioned Legislative Decree has also implemented the RoHS 2002/95/CE Directive. The Restriction of the use of certain Hazardous Substances (RoHS) in electrical and electronic equipment.

As from 1st July 2006, all new electrical and electronic equipment put on the market must not contain, or contain limited quantities of, certain substance, namely: Lead, Mercury, Cadmium, Hexavalent chromium, Polybromide biphenyls (PBBs), Polybromide diphenyl ethers (PBDEs).

---

## Edizione giugno 2011

Concept and graphic design: Anna Silvestrini

Edition 2011

Photography: Daniele Di Pietro

Stylist: Sara Sarli

Images retouching: Simone Marcuzzo

Print: GFRit

Thanks to:

FLOORCOVERING By Dal Santo Flavio, MARSURA SALVINO SCULTORE, TIVOLI AUDIO

LUCENTE SRL

Via Piemonte 1/A  
31038 Padernello di Paese  
Treviso - Italy

Tel. +39 0422 4575  
Fax +39 0422 950720

[info@lucente.eu](mailto:info@lucente.eu)  
[www.lucente.eu](http://www.lucente.eu)